

Bulletin of the
Indus
Research
Centre

ROJA MUTHIAH RESEARCH LIBRARY

No. 2 | August 2011

BULLETIN OF THE INDUS RESEARCH CENTRE

No. 2, August 2011

Indus Research Centre
Roja Muthiah Research Library
Chennai, India

The Indus Fish Swam in the Great Bath :
A New Solution to an Old Riddle

Iravatham Mahadevan



Indus Research Centre
Roja Muthiah Research Library

© Indus Research Centre, Roja Muthiah Research Library, August 2011

Published with financial assistance from the
Central Institute of Classical Tamil, Government of India
Vide Sanction No.F.11-264/2009-10/CICT/Projects/1778 November 10, 2009

Title page illustration : Grayware Bowl with Swirling Fish Motif. Mehrgarh.
(Courtesy : Fig. 2.12 J.M. Kenoyer 1998. Ancient Cities of the Indus Valley Civilization,
Oxford University Press).

CONTENTS

PART I : FISH SIGNS OF THE INDUS SCRIPT*

I.	FISH Signs	01
II.	The 'Great Bath' at Mohenjodaro	14
III.	West Asian parallels	21
IV.	Indo-Aryan parallels	23
V.	Dravidian parallels	24
VI.	Interpretation of the FISH Signs	30

* Part II of the paper titled 'The Sacred Pool (Great Bath) and associated Structures in the Indus Texts' will be published later in a Bulletin of the Indus Research Centre, Roja Muthiah Research Library, Chennai.

**The Indus Fish swam in the Great Bath :
A New Solution to an Old Riddle**

Iravatham Mahadevan

PART I : FISH SIGNS OF THE INDUS SCRIPT

I. FISH signs of the Indus Script

1.1 The FISH signs stand out prominently in the Indus texts (Fig. 1.1). They occur with high frequency and occupy nearly ten percent of the total textual matter.







FISH signs							
Frequency	381	216	279	73	188	76	67
Alphabetic Index	A	B	C	D	E	F	G
Conventional Labels	FISH	+ roof	+ rays	+ vertical stroke	+ slanted stroke	+ rake	+ two tall lines

Fig.1.1 FISH Signs in the Indus Script (ASI Concordance 1977)

The striking resemblance and almost identical positional distribution of the FISH signs in the Indus texts make it reasonably certain that they must have similar or related meanings. It is also clear from their pictorial depiction that the modifications and additions to the FISH signs (B to G in Fig.1.1) do not represent natural varieties of the fish. This consideration alone would rule out literal interpretations like the ‘carp’ (Gurov in Knorozov et al 1968 : p.40) or ‘fish rations’ (Kinner Wilson 1986). Daily business transactions are unlikely to be carved in *intaglio* on expensive and durable stone seals. The suggestion by Hunter (1934 : p.75) that the FISH signs are syllables sharing the same consonant but with varying vowels is contradicted by the occurrence of different FISH signs in the same context. You cannot replace, say, ‘pan’ with ‘pen’ or ‘pin’ or ‘pun’ in the same context. The distributional statistics of similar signs with minor modifications in the Indus texts favours ideographic interpretation (Mahadevan 1986a). The prominence and high frequency of the FISH signs on the seals indicate that the signs represent some important aspect of the Indus polity.

The Heras Conjecture

1.2 Attempts to decipher the Indus Script on the basis of the Dravidian hypothesis began with Father Henry Heras. And his decipherment began virtually with the FISH sign. He pointed out that the word for ‘fish’ in most Dravidian languages is *m̄n* which also means ‘star’ (Heras 1953 : p.100). All ancient pictographic scripts employed the technique called rebus, by which a picture sign can be read with another meaning suggested by the same sound. (For example, the picture of an ‘eye’ can be read as ‘I’, first person singular pronoun, if the language is English.) Heras suggested that the FISH sign in the Indus Script can be read as *m̄n* but with the meaning ‘star’ in Dravidian (Fig. 1.2).

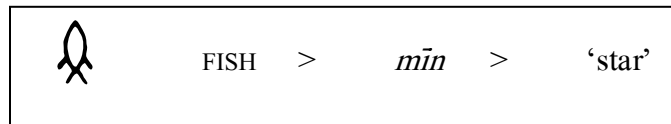

Fig.1.2 The Heras Conjecture

In support of his interpretation, Heras (1953 : p.127) cited the Old Tamil word *aru-m̄n*, literally ‘six fish’, but with the meaning ‘six stars’ (*Krittikā*, the Pleiades constellation). The sign combination 6+FISH does occur frequently in the Indus texts (Fig. 1.3). This simple but persuasive idea has remained ever since the ‘central dogma’ of the Dravidian hypothesis on the Indus Script.



Fig.1.3 6+ FISH sequence on an Indus Seal (Harappa.Vats: No.256)



Fig.1.4 Realistic depiction of the FISH on an Indus Seal (National Museum: 135)

Extending the Heras Conjecture

- 1.3 The Russian group of scholars led by Yuri V. Knorozov (from 1965), the Finnish team led by Asko Parpola (from 1969), and later, Asko Parpola himself (in a series of papers culminating in his *magnum opus* in 1994), have systematically extended the Heras Conjecture to other NUMBER + FISH combinations in the Indus texts with striking parallels in Old Tamil names for constellations (Fig. 1.5).



SIGN SEQUENCE	Literal meaning	Old Tamil attestation	Intended meaning	Constellation
 III	3+ FISH	<i>mum-mīṅ</i>	‘three stars’	Mrigaśiras
 III	6+ FISH	<i>aṛu-mīṅ</i>	‘six stars’	Krittikā
 III	7+ FISH	<i>eḷu-mīṅ</i>	‘seven stars’	Sapta-rishi

Fig.1.5 Extending the Heras Conjecture to other constellations

(After Knorozov et al 1979 :p.93, and Asko Parpola 1994 : p.275)

However, attempts by Dravidianist scholars including Heras himself (1953), Knorozov et al (1979), Asko Parpola (1994) and Iravatham Mahadevan (1970) to interpret the ‘modified fish’ signs (B to G in Fig. 1.1) as various ‘stars or planets’ have evoked little response, as the scholars are not in agreement and the proposed identifications lack the simplicity and elegance of the original Heras Conjecture. Clearly, the FISH > *mīṅ* > ‘star’ theory had run out of steam and needed reappraisal.

Revolt by Fairservis

- 1.4 The distinguished American archaeologist, late Walter A. Fairservis, published his Dravidian model of decipherment of the Indus Script in 1992. Fairservis rejected altogether the idea that the sign in question depicted the ‘fish’, and proposed an alternative identification that the sign is derived from a ‘knot or twist in a loom’ (Fairservis 1992 : pp.50-51). However, the sign is too realistically modelled on the ‘fish’ and convincingly supported by pictorial parallels in the Indus art (Fig.1.4) to be dismissed so summarily. By rejecting the identification

rather than the interpretation of the FISH sign, Fairservis had thrown the baby out with the bathwater.

My earlier study of the FISH signs

- 1.5 I began working on the Indus Script in 1968 and published my first paper (Dravidian Parallels) in 1970. I embraced the Heras Conjecture with enthusiasm and welcomed its logical extension to other constellations by the Russian and the Finnish scholars. I also proposed my own interpretations of the ‘modified’ FISH signs (B to G in Fig. 1.1). But, after the publication of the ASI Concordance (1977) and a systematic study of the texts through statistical-positional analysis, I became increasingly disenchanted with the Heras Conjecture.

Problems with the Heras Conjecture

- 1.6 Before I proceed further to explain my new approach, I shall set out briefly the main reasons for my disillusionment with the Heras Conjecture:
- (i) Most Indus texts are engraved on seals which offer very limited space for writing. The seal-engravers had to practise the utmost economy, which they did by fashioning mostly tall and narrow signs and squeezing the broader signs (turning ‘diamonds’ into ‘ovals’) or even rotating the signs from horizontal to vertical position, as in the case of the FISH signs themselves (compare the FISH in Figs.1.3&1.4). In this milieu, it seems most unlikely that ‘stars’ would be represented by the bulky FISH signs (which often occur in pairs and sometimes even as triplets). One would expect a star to be depicted much more naturally and economically by a small asterisk-like sign (*), an artistic convention known to the Indus art.
 - (ii) The NUMBER + FISH signs appear to be part of a larger system of NUMBER + SIGN sequences in the Indus texts. In all these cases, signs are preceded by varying numbers (from 3 to 9) indicated by short vertical strokes arranged in one or two tiers (Fig. 1.6).

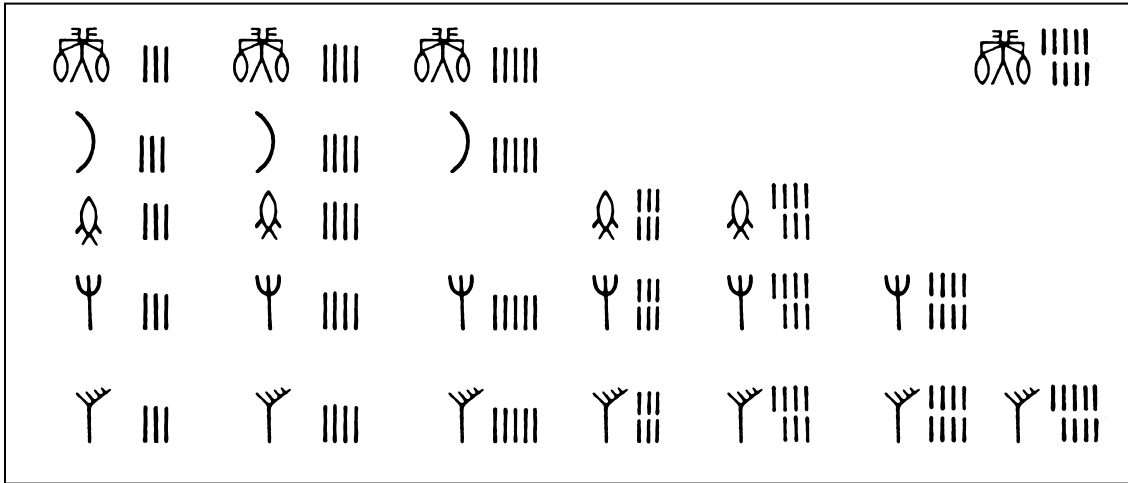

Fig.1.6 NUMBER + SIGN sequences in the Indus Texts

It seems most unlikely that among the many NUMBER + SIGN sequences in the Indus texts, the FISH group alone represents constellations in the sky, while all other sequences refer to various entities on earth.

- (iii) Several distinguishing features of the FISH signs remain without convincing explanation by the FISH > ‘star’ theory. I shall be dealing with three of them in the course of this paper, viz., the special affinity of the FISH signs to the four-stroke modifier, the ARROW and the MORTAR & PESTLE signs. Indeed, as we shall see from the sequel, these three features hold the key to the correct interpretation of the FISH signs.

Towards an Alternative Solution

- 1.7 These considerations have led me to believe that the similarity between the NUMBER + FISH sequences in the Indus texts and the Old Tamil names for constellations is merely fortuitous. As I had no alternative explanation to offer, I refrained from writing on the FISH signs after the publication of the ASI Concordance in 1977 with one exception. I published a paper on the ‘Grammar of the Indus Script’ (1986a) in which I included a theorem on the behaviour of the FISH signs based on statistical analysis of their frequency and distribution. I shall summarise the result here as it has turned out to be the first step towards the new interpretation of the FISH signs.

Identification of the four-stroke modifier of the FISH signs

- 1.8 One of the shared features of the FISH signs is their further modification by the addition of a set of four short vertical strokes placed symmetrically around each sign (Fig. 1.7). The set of strokes is described as a ‘modifier’ as it does not occur as an independent sign.

	A	B	C	D	E	F	G
FISH signs							
+ four-stroke modifier							

Fig.1.7 FISH signs modified by four strokes

Knorozov et al (1979 : pp.8,19) proposed that the four strokes surrounding the FISH signs can be interpreted as an adjective qualifying the meaning of the signs. It is known that the adjective precedes the noun in the Indus texts. (See Fig. 1.6 where the numbers preceding the signs can be regarded as adjectives.) The Russian scholars also proposed that the four strokes may be read as *nāl* ‘four’ and interpreted through rebus as *nal* ‘good’ in Dravidian. According to this interpretation, the four-stroke modifier has to be read before the FISH words. But this interpretation is unable to explain why the FISH signs, which occur mostly in the middle of the texts, shift mostly to the final position when the four-stroke modifier is added to them. Further analysis shows that the same shift occurs when the ARROW and the JAR signs, known to function as grammatical suffixes, are added to the FISH signs. Furthermore, when the four-stroke modifier is added, the FISH signs are never followed by the ARROW or JAR signs. On the basis of this evidence, I published a revised interpretation (1986a) proposing that the four-stroke modifier is a grammatical suffix alternating with the ARROW and the JAR signs and must therefore be read after the FISH words and not before. I also identified the four-stroke modifier on the basis of its function as the plural suffix. This suggestion had been made earlier by Heras (1953 : pp.83-84) but from parallels in the Egyptian hieroglyphic script.

Identification of the ARROW sign 

- 1.9 The ARROW sign is easily identified by its shape. Statistical analysis has shown that it functions as a grammatical suffix like the JAR sign. These suffixes are unlikely to be case markers which do not occur in text-final position in Dravidian as shown by the earliest Tamil-Brāhmī inscriptions and coin- and seal legends from ca. 2nd century B.C.E. (Mahadevan 2003). This leaves the only possibility that these signs are nominal or pronominal suffixes serving as gender-number markers which are combined in Dravidian. But my earlier suggestion (1970) that the ARROW sign is a masculine or epicene singular suffix has turned out to be incorrect. I discovered later, as narrated below, that the ARROW sign is the non-masculine singular suffix.
- 1.10 In August 1995, I was at the library of the Directorate of Epigraphy in Mysore collecting material for my book *Early Tamil Epigraphy* (2003). One day when I was browsing through the *Historical Grammar of Telugu* by Korada Mahadeva Sastri (1969 : pp. 135-136), I came across the passage describing gender suffixes in Old Telugu including *-(a)mbu*. I saw in a flash that here was the perfect rebus between the phonetic value of the ARROW sign (*ampu* ‘arrow’; DEDR 178) and its function as the non-masculine singular suffix. I published the discovery in 1998 (Fig. 1.8).

SIGN	Pictorial identification	Dravidian equivalent	Phonetic value through rebus	Intended meaning
	ARROW	<i>ampu</i>	<i>-(a)mp(u)</i>	Non-masculine Singular suffix

Fig.1.8 Interpreting the ARROW sign of the Indus Script

The ARROW points to the JAR 

- 1.11 An important consequence of the determination of the function and the phonetic value of the ARROW sign is the bearing it has on the interpretation of the JAR sign.



Fig 1.9 JAR sign on pottery from Kalibangan.

It is well-known that the JAR is by far the most frequent sign in the Indus Script. It functions like a grammatical suffix in the same manner as the ARROW sign. Since the ARROW sign has been shown to be the non-masculine

singular suffix, it follows almost automatically that its more frequent twin, viz., the JAR sign, must be the masculine singular suffix. This result is virtually independent of the pictorial identification or the phonetic value of the JAR sign. I have interpreted the JAR sign as depicting a ‘vessel with handles’ (1970). The pictorial identification of the JAR sign has been confirmed by the discovery of pottery graffiti at Kalibangan (Fig. 1.9) realistically depicting the sign as a jar with handles (Lal 1979).

- 1.12 I have also been able to determine the phonetic value of the JAR sign as $-(a)\underline{nr}(u)$ on the basis of comparison with masculine singular suffixes in the earliest Old Tamil and Old Telugu inscriptions, and also through rebus with ‘vessel’ words in Dravidian. (For details, see Mahadevan 1970, 2009b & 2010.)

Some of the earliest inscripational attestations of Old Telugu gender-number suffixes $-(a)\underline{nr}(u)$ and $-(a)mb(u)/-(a)mp(u)$ are known from the cave inscriptions of Mahendra Pallava (590-630 C.E.). (See Fig. 1.10). The title in Old Telugu means ‘one who (wields) the noose in battle’. Note that $-\underline{nr}(u)$ indicates the masculine gender of the person and $-mb(u)$ indicates the neuter gender of the object (*pāśā*).

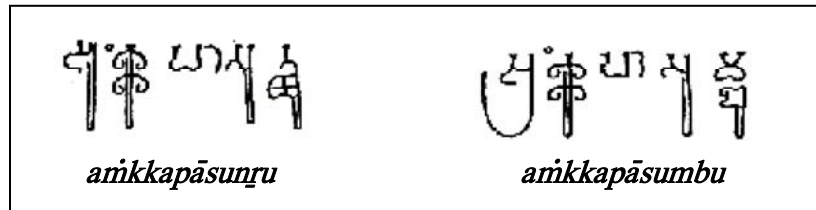

Fig.1.10 Old Telugu Inscriptions of Mahendra Pallava
(after Michael Lockwood 2001 : p.199)

Gender-Number Paradigm in the Indus Texts

- 1.13 Identification of the three suffixes has led to the formulation of gender-number paradigm in the Indus texts (Mahadevan 2009b & 2010) See Fig.1.11.



SIGN	Pictorial Identification	Phonetic value in Dravidian	Grammatical category
	JAR	<i>-(a)nr(u)</i>	Masculine (human male) singular suffix
	ARROW	<i>-(a)mp(u)</i>	Non-masculine (human female + non-human) singular suffix
	Four-stroke modifier	<i>-(a)r</i>	Epicene (human male and/or female) plural suffix

Fig.1.11 Paradigm of Gender-Number Suffixes in the Indus Texts

The suffixes cannot, by definition, occur as solus or in the initial position in the texts. They cannot also occur as identical pairs, nor any two of them side by side. (For a list of gender, number and case suffixes and discussion on apparent exceptions, see Mahadevan 1986a.)

Dual values of JAR and ARROW signs

- 1.14 The relatively small number of signs in the Indus Script would make it almost obligatory that many of the signs possess more than one value derived from literal pictographic meanings as well as through phonetic transfer by the rebus method. The JAR and ARROW signs provide the best illustrations for this hypothesis. These two signs possess, in addition to their grammatical function, literal ideographic values also (Mahadevan 1998, 2009a&b). Thus the JAR sign depicts a ‘sacrificial vessel (with food offerings)’; the ARROW sign stands for an ‘arrow-head or lance-head’ or ‘weapons’ in general. The dual values of the two signs are clearly indicated in the compound signs JAR-BEARER and ARROW-BEARER, where they occur as the initial elements (Fig.1.12). The present paper dealing with the interpretation of FISH signs includes only the grammatical functions of the JAR and ARROW signs as gender-number suffixes.

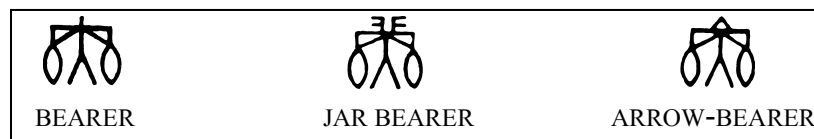

Fig.1.12 Ideographic interpretation of JAR and ARROW signs

Appellative Nouns with Gender suffixes

- 1.15 A study of ideographic word signs in the Indus texts reveals the presence of appellative nouns which are formed from nominal or adjectival stems by the addition of pronominal suffixes. The following examples are from the earliest Tamil cave inscriptions of ca.2nd-1st centuries B.C.E. (Mahadevan 2003 : p.146) :

kaṭal ‘sea’ > *kaṭal-aṇ* ‘he of the sea’

kōṭu ‘hill’ > *kōṭ-aṇ* ‘he of the hill’

This pattern can be matched from the following examples in the Indus texts (fig.1.13)

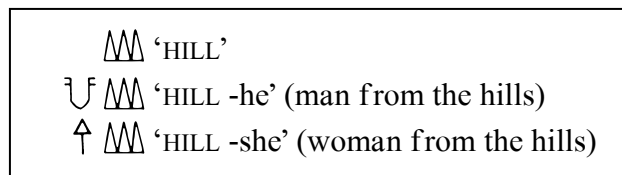

Fig.1.13 Appellative nouns in Indus Texts

Note that in these examples, the suffix marks the gender of the appellative noun and not of the stem from which it is formed.

Asymmetry in the Paradigm : Clue to the gender of the FISH words

- 1.16 A remarkable feature of the gender-number classification in Early Dravidian is the gender overlap : ‘she’ is non-masculine in the singular and clubbed with the non-human ‘it’, but is feminine in the plural and clubbed with the human ‘they’ (men and women). Gods and goddesses were included in the ‘high category’ with the human and shared the same gender classification. There was no separate feminine gender. This asymmetrical pattern is preserved in Telugu :

vāṇḍu ‘that man’

adi ‘that woman, thing’

vāru ‘those persons’ (men and/or women)

avi ‘those things’

The creation of a separate feminine gender (as in Tamil *avaḷ* ‘she’) was a later innovation. (This is a simplified summary of a rather complex linguistic development in Dravidian. For the best account, see Bh. Krishnamurti 2003: pp.205-217).

1.17 The frequency-distribution of the three nominal/ pronominal suffixes in the Indus texts is found to match the Early Dravidian gender-number categories described above and illustrated in the paradigm (Fig. 1.11). The peculiar asymmetry or gender overlap provides the critical clue to determine the true (biological) gender of the FISH words when followed by the ARROW suffix. The ambiguous ‘non-masculine’ classification of the FISH-ARROW sequence can be restricted to the more precise ‘feminine (human female) ’ gender, as the four-stroke modifier alternating with the JAR and ARROW suffixes represents only the human (men and/or women) plural (Fig.1.14).



Grammatical category	Sign sequence (FISH + suffix)	Phonetic value (of the suffix)	Interpretation (of gender & number)
Masculine Singular		FISH-(a) <u>nr</u> (u)	‘FISH-he’ (man)
Feminine Singular		FISH-(a) <u>mp</u> (u)	‘FISH-she’ (woman)
Epicene Plural		FISH-(a)r	‘FISH-they’ (men and/or women)

Fig.1.14 Identification of Gender and Number of FISH signs from the suffixes

Improbable Sex ratio among FISH Signs : Another clue to their identity

1.18 Men and women are born in equal numbers, but women have never enjoyed equal share of power with men. The Indus polity is unlikely to have been an exception to this universal pattern of male dominance. Animals and anthropomorphic figures on the Indus seals and sealings are almost exclusively male. The gender suffixes in the Indus texts confirm this pattern – but with a couple of surprises. The overall ratio of occurrences of the JAR and ARROW signs in the Indus texts is about 6 : 1. This ratio does confirm male dominance in the Indus society, but not quite on the scale indicated in later records. The earliest Tamil cave inscriptions (ca.2nd century B.C.E-6th century C.E.) record 108 personal names and titles out of

which only 6 are those of women (Mahadevan 2003: Appendix II). An even closer parallel would be the seals and rings of the Early Historical Period (ca.1st century B.C.E.-3rd century C.E.) engraved with personal names and titles in Tamil or Prakrit found in large numbers in recent years from ancient sites in Tamilnadu; not one of them bears a female name. Judged against this historical background, the proportion of about 15 percent ‘non-masculine’ nouns ending with the ARROW suffix in the Indus texts is surprisingly high and calls for an explanation. Some sequences ending with the ARROW suffix may denote words in the neuter gender. But the FISH words are not among them as indicated by the four-stroke modifier attached to them in the plural number, placing them in the human category (Figs 1.7 & 1.14) .

1.19 The second and even more surprising feature is the apparent dominance of the female over the male in the category of FISH signs as shown by statistical analysis (Fig.1.15).

















FISH -ARROW Sequence (Fem. Sg.)		FISH - JAR Sequence (Masc. Sg.)		FISH + Four stroke Modifier (Epicene Pl.)	
	Frequency		Frequency		Frequency
↑ 	55	∩ 	44		29
↑ 	5	∩ 	6		19
↑ 	27*	∩ 	21		9
↑ 	10	∩ 	3		7
↑ 	24	∩ 	10		8
	-----		-----		-----
	121		84		72

Fig.1.15 Frequency of FISH with ARROW, JAR and Four-stroke Modifier suffixes (ASI Concordance 1977) . *Note : Including , now regarded as variant of .

FISH-women outnumber FISH-men by three to two. If frequency of occurrence of names and titles on seals is considered an index of the relative importance of the seal-holder, FISH-women clearly outranked the FISH-men in the Indus polity.

FISH Signs : Summary of the new findings

- 1.20 The discovery of gender-number suffixes in the Indus texts and frequency-distribution analysis of the FISH sequences ending with these suffixes lead to the following preliminary conclusions :
1. FISH signs represent a special category of persons in the Indus society.
 2. FISH-women appear to be more important than fish-men within the special category.
 3. FISH -women are accorded a prominent place among the seal-owning ruling classes.
 4. The fact that there are only seven fish signs, each of them occurring also with the plural suffix (Fig.1.7), indicates that the fish words are not proper names, but appear to be common nouns indicating titles (attributes) or categories like classes or groups.

Clue to the identity of FISH Signs

- 1.21 The conclusions summarised above lead to further questions: who were the FISH - women? How did they acquire the prominence accorded to them in the seal- texts? Why do women appear to outrank men in this group? It turns out that the answers to these questions can be found from the interpretation of the so-called 'Great Bath' at Mohenjodaro considered in the next Section.

II. The 'Great Bath' at Mohenjodaro

The 'Great Bath' : A Sacred Pool

- 2.1 The so-called 'Great Bath' at Mohenjodaro is the most famous but least understood monument of the Indus Civilisation. I shall not dwell on its well-known and often-described architectural features except to highlight those aspects relevant to the present study. One can get a 'feel' of this remarkable structure and the imposing buildings surrounding it from the authentic reconstructed view published by Marshall (1931) and reproduced here in Fig.2.1.
- 2.2 Marshall described the whole structure as "a vast hydropathic establishment" and "a large swimming bath". According to Mackay (in Marshall 1931 : p.142), the pool was "a large bath where numbers of people could gather together to bathe", comparable to a 'Roman Bath'. These ideas are incongruous and betray lack of familiarity with the Indian tradition of 'temple tanks'. Wheeler (1960: pp.31-33) was closer to the truth when he pointed out that "the whole complex related to the religious life of the City or its rulers".
- 2.3 Since almost every house in Mohenjodaro had a bathroom, there should have been no need for a public bath; nor would such a bath be located on the top of the Citadel Mound, requiring laborious manual filling with water drawn from a well, when it could have been constructed much more conveniently, and with much less labour and cost, on the plains below connecting it to the Indus river flowing nearby. Even Wheeler's idea of a temple tank for ablution like those of 'modern Hinduism', does not fully explain the peculiar features of the structure. These include 'a great enclosing wall' which restricted free access to the facility, and a set of bathrooms with doorways located in such a manner that none opened opposite to another, thus ensuring privacy. Mackay's explanation that the priests performed their ablution in the bathrooms while the general public performed theirs in the Great Bath appears incompatible with the archaeological evidence.
- 2.4 It appears to me that the true function of the pool and the elaborate structure associated with it can be understood only on the supposition that the whole complex was an integral part of the religious-cum-power centre on the Citadel

Mound, the core of which now lies hidden under the Kushāṇa Stūpa (ca.2nd century C.E.) built over its ruins. In short, the so-called ‘Great Bath’ was a Sacred Pool for ritual bathing by the priests and priestesses of the Temple. This is not a new discovery of mine. Kosambi had made out a persuasive case for this hypothesis in his paper ‘Urvaśī and Purūravas’ (1951), later incorporated as a chapter in his book (1962: pp.42-81). What is new in the present study is that Kosambi’s interpretation of the function of the ‘Great Bath’ has led to the identification of the FISH signs in the Indus Script, and going beyond it, to new insights into the religion of the Indus Civilisation and survival of the rituals in later times.

The Kosambi Conjecture : *pushkara* and its functions

2.5 Kosambi (1965 : pp.66-68) considered the main architectural features of the ‘Great Bath’ and concluded that the purpose of the structure was for some ‘elaborate ritual’ considered vital by the inhabitants. He identified the pool as a ‘ritual tank’ similar to the *pushkara* ‘lotus pond’ of later times, which served three main functions, namely -

1. For consecration of kings and priests with ‘sprinkling’ water on them.
2. As a pilgrim spot, *tīrtha* (water to be crossed by fording) with *ghat* (steps leading to the water).
3. For primitive fertility rites.

It is the third function identified by Kosambi, which is central to the present study. I shall quote in full Kosambi’s own account (1965: p.68) :

“... In the very oldest references there is described a third function of the *pushkara* which associates it with primitive fertility rites. These lotus-ponds were generally the resort of a special class of water-deities or water-witches, the *apsaras*. The *apsaras* are described as irresistibly beautiful women who would entice men to consort with them and eventually lead the heroes to destruction. These bathing beauties were also accomplished in song and dance. The demi-goddesses had individual names and each was associated with some particular locality. Several ancient Indian dynasties were supposed to have descended from the temporary union of some particular *apsaras* with a hero. The *apsaras* could not marry a husband and settle down to permanent, normal married life.

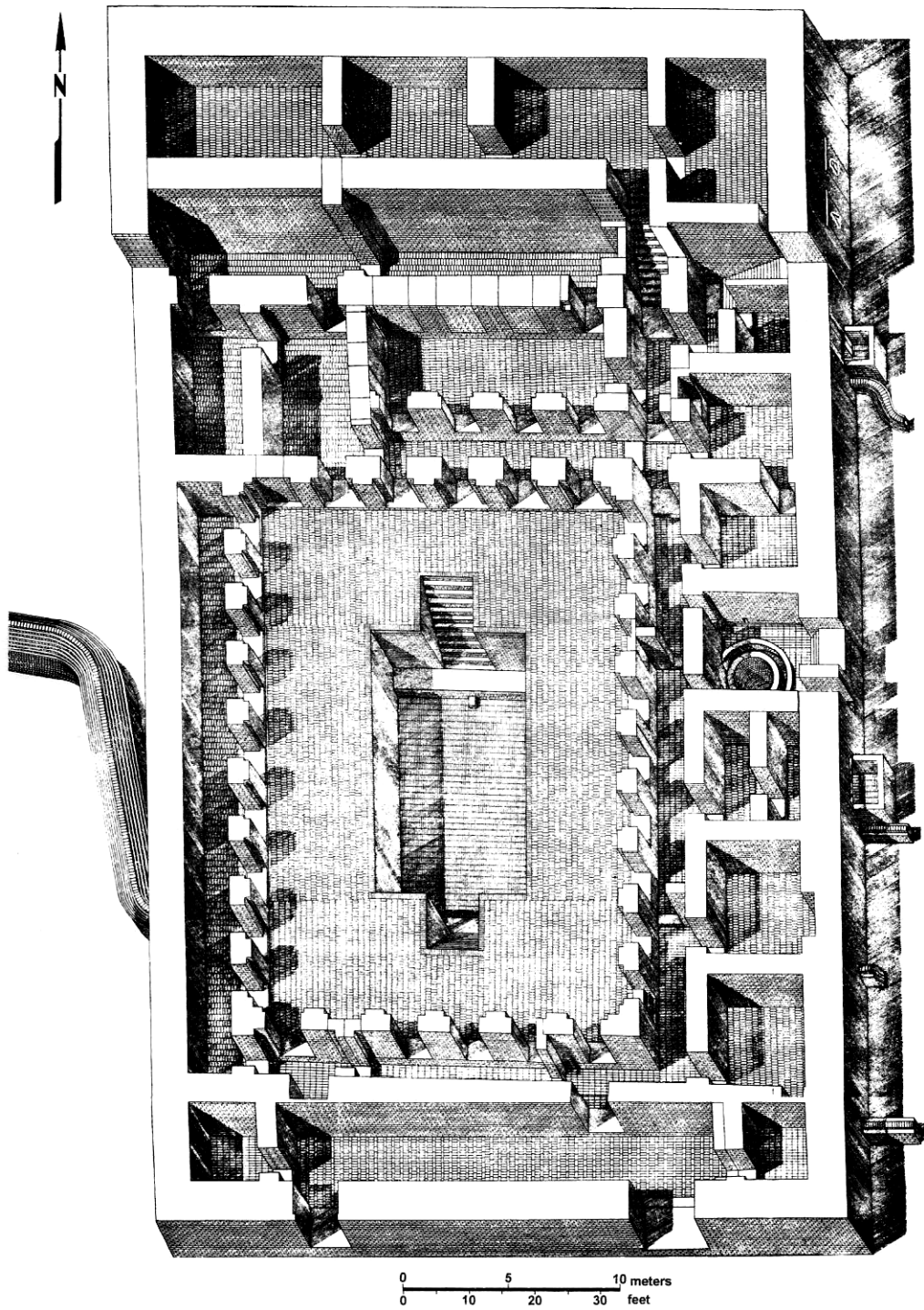

Fig.2.1 The Great Bath at Mohenjodaro (Marshall 1931)

This would explain the use of the peculiarly constructed rooms at the ‘Great Bath’. It was part of the ritual for men not only to bathe in the sacred water but also to cohabit with the female attendant representatives of the mother goddess to whom the citadel complex belonged. This is not far-fetched. The temples of Ishtar in Sumer and Babylon had similar practices in which girls of the leading families had also to participate. The goddess Ishtar was herself eternal virgin and harlot at the same time, mother goddess but not wife to any god. She was also the goddess of the river. The Citadel Mound was, in fact, the Indus counterpart of the Mesopotamian Ziggurat”. (Emphasis added by me-I.M.)

Indian Fish-god and the Mesopotamian Merman and Mermaid

- 2.6 Kosambi (1962 : pp.20-22) traces the origin of the Fish incarnation of Vishṇu as well as Nārāyaṇa (‘he who sleeps upon the flowing waters’) to the universal flood-and-creation myths. He points out that the conception of Nārāyaṇa is precisely the same as the Mesopotamian Ea or Enki ‘who sleeps in his chambers in the midst of the waters’. It is in this context that he remarks, “The Fish has its Mesopotamian counterparts”, and illustrates his suggestion with a Mesopotamian button seal depicting a fish-like merman and mermaid pair. I reproduce the line-drawing and the photograph of the button-seal (Fig.2.2) which, according to me, supplies the missing link between the ‘Great Bath’ and the FISH signs of the Indus Script.



Fig.2.2 Mesopotamian button-seal depicting a fish-like merman and mermaid pair. (After Kosambi 1962 : Fig 1.4 ; 1965 : Pl.51.)

‘The Indus Fish swam in the Great Bath’ : Solution to the riddle of the FISH signs

- 2.7 I propose, on the basis of the evidence from my analysis of the FISH signs in the Indus texts (summarised in the first section of this paper), and Kosambi’s

interpretation of the ‘Great Bath’, that *the FISH signs are ideograms representing the water nymphs whose activities centered round the Great Bath*. The Indus water nymph closely corresponds to the Mesopotamian hierodule (Greek for ‘sacred servant’) and to the *apsaras* and the *gandharva* mentioned in the *RV* and later Sanskrit literature. I shall also draw parallels with Old Tamil *ara-makaḷir* ‘divine damsels’ and the *dēva-dāsī* (‘servant-maids of god’) attached to the larger temples in South India in the medieval period.

- 2.8 I discovered the meaning of the FISH sign on 19th May 2007, when I was reading again Kosambi’s writings on the Indus Civilisation during his centenary year. I have never ceased to marvel since then at the appropriateness, elegance and simplicity of the visualisation of the water nymphs attached to the Great Bath as the ‘fish’. The signs depicting the fish in erect standing posture (Fig.1.1), apart from saving the space on seals, do manage to convey subtly the imagery of sleek dancing damsels (described by Kosambi as ‘the bathing beauties’). The anthropomorphic character of the FISH sign is corroborated by the unique compound sign incised on a terracotta object from Kalibangan (Fig.2.3.a). The graffito incised on the oval-shaped object is a compound of five basic signs (Fig. 2.3.b), in which the ‘standing man’ of the BEARER sign (2.3.c) is replaced by the ‘standing’ FISH.

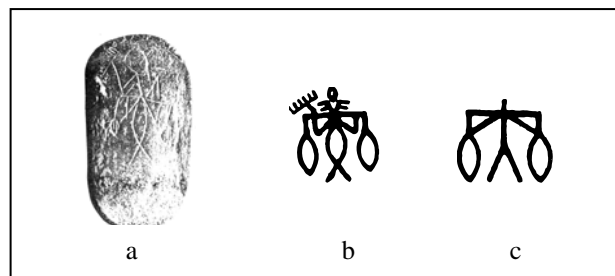

Fig.2.3 (a) compound sign incised on a terracotta object from Kalibangan (CISI-EK-79)

(b) drawing of the compound sign (ASI Concordance 1977 : p.25)

(c) The BEARER sign.

Dancing Girls from Mohenjodaro

- 2.9 The Indus texts depict the water nymphs symbolically in the form of the FISH signs. The two well-known figurines of bronze dancing girls found at Mohenjodaro may be identified as realistic depiction of the water nymphs (Fig.2.4 a & c).

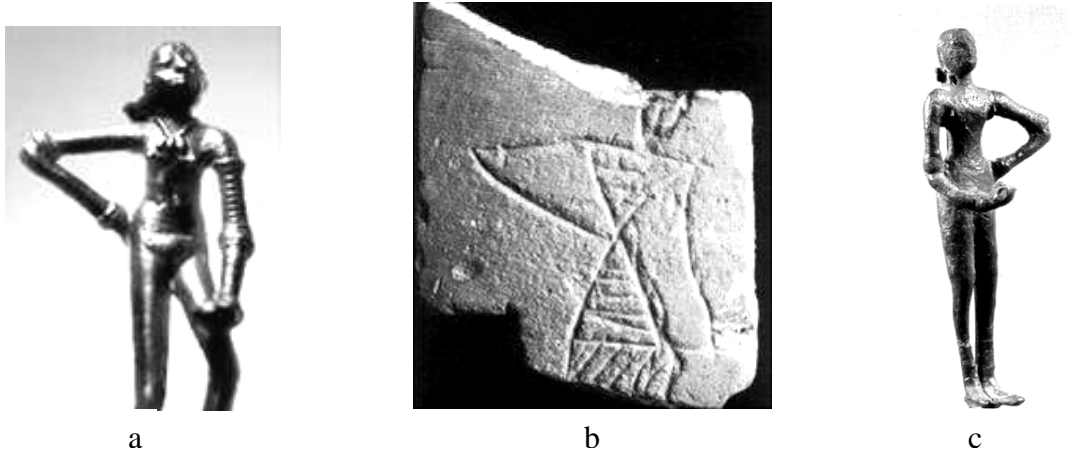

Fig.2.4 Dancing Girls. (a&c) Bronze figurines from Mohenjodaro (Marshall 1931); (b) pottery grafitto from Bhirrana (L.S. Rao 2007).

According to Marshall (1931 : p.45), the better known bronze (Fig. 2.4.a) “gives a vivid impression of the young aboriginal nautch girl, her hand on hip in a half-impudent posture, and legs slightly forward, as she beats time to the music with her legs and feet.” Wheeler called the bronze his ‘favourite statuette’ and gives the reason why : “There is her little Baluchi-style face with pouting lips and insolent look in the eye. She’s about fifteen years old I should think, not more, but she stands there with bangles all the way up her arm and nothing else on. A girl perfectly for the moment, perfectly confident of herself and the world. There’s nothing like her, I think, in ancient art” (quoted in Possehl 2003: p.114). Possehl’s own comment is also worth quoting : “one sees a subtlety to the expression and pose that defies description and cannot be captured by the camera. In spite of the stylised, even abstract, nature of the figure, there is a sense of ‘impudence’ as Marshall noted, certainly youthful superiority, self-confidence, even arrogance”. Altogether, a perfect picture, I may add, of the *apsaras*, joyful, free and uninhibited.

The Dancing Girl from Bhirrana

- 2.10 A red potsherd with an engraving that resembles the iconic bronze figurine of Mohenjodaro was discovered in 2004-5 during the excavations of the Harappan site at Bhirrana in Haryana (Fig.2.4.b). L.S.Rao of the Archaeological Survey of India, who led the excavation team, has published the rare find (2007). According to Rao, the stance of the figure engraved is so true to the original bronze dancing girl of Mohenjodaro that it appears that the craftsman of Bhirrana had first-hand knowledge of the former. Rao describes the figure on the potsherd as follows : “here too, the right hand is akimbo, and the left is suspended by its side. Slight oblique strokes on the right upper arm are suggestive of the presence of armlets. The lower portion of the body is missing owing to damage on the sherd. The clothing is indicated by horizontal hatchings on the chest and abdomen, and vertical hatchings on the thighs.” This rare find indicates that the Great Bath of Mohenjodaro had its counterparts at other Harappan sites as well, though most probably on a more modest scale. The occurrence of the FISH signs on the seal texts found at most Harappan sites also confirms this fact.

Numismatic motif of water tank with fish

- 2.11 The rectangular tank with a school of fish swimming in it is a motif found on the silver punch marked coins of the early historical period.



Fig.2.5 Motifs on a silver punch-marked coin including that of a water tank with fish.
(Kosambi 1965 : p.129, Fig.10)

I reproduce the illustration (Fig 2.5) from Kosambi’s famous study of the silver punch-marked coins proving that they had a weight system going back to the Indus Valley. This particular coin has been identified by him as probably that of Ajātaśatru, ca.480 B.C.E. (Kosambi 1965 : p.129). The numismatic motif of the rectangular water tank with a school of fish swimming in it is most probably a survival of the memory of similar ritual tanks of the Indus Age. (See also Fig. 5.4 below.)

III. West Asian Parallels

Inanna, the Sumerian goddess of love

- 3.1 Sumerian temples were built on the top of rectangular stepped towers called the Ziggurat. Cuneiform inscriptions on clay tablets tell about the sacred rituals in the precincts of the temple. The Sumerian goddess of love was known as Inanna, the Queen of 'Heaven and Earth' and goddess of 'Morning and Evening Star'. She was attended upon by the hierodules whose function included sexual rites. The principal religious rite was *hieros gamos* 'sacred marriage', when the goddess of love represented by the High Priestess was married to the god represented by the reigning king acting as the god's surrogate. The god was the consort of the goddess, husband-lover-son at the same time, and was subordinate to her. The sex act was considered sacred and "there was no separation between sexuality and spirituality" (Qualls - Corbett 1988 : pp.21-51).

Ishtar, the Babylonian goddess of love

- 3.2 The Babylonian goddess of love was Ishtar, the 'great goddess' and 'mother of harlots'. She was the eternal virgin as well as hetaera. She was associated with the rising and setting of the Sun, as the 'Morning star', Venus. Ishtar was also known for her cruelty and fickleness towards her lovers. Herodotus, the Greek historian writing in the 5th century B.C.E., describes the Babylonian custom according to which every woman of the land had to sit in the temple once in her lifetime to have sex with a stranger. The sex act purified her and she returned home to lead a normal married life.

The Code of Hammurabi

- 3.3 There were also other hierodules who did not wish to enter into the bondage of matrimony and spent their entire lives in the sacred cloister within the temple compound. They were highly educated and accomplished in song and dance. The Babylonian Code of Hammurabi (18th century B.C.E.) had special provisions to protect their legal rights, including the right to own and dispose of property.

Gilgamesh and Enkidu

- 3.4 The theme of sacred sex is woven into the Babylonian Epic of Gilgamesh. He spurned the sexual advances of the goddess Ishtar. The gods decided to teach him a lesson, and sent Enkidu, a wild hairy man, into the world. Gilgamesh planned to capture him and sent Herem, the beautiful courtesan, to entice him at the watering hole. Enkidu had sex with her for ‘six days and seven nights’ and was tamed. Thereafter Herem led him to the gates of the city.



**Fig.3.1 Gilgamesh-like figure
on Indus Seal.
(Mohenjodaro. Mackay : No.86.
Kosambi 1965 :Pl.49)**



**Fig.3.2 Enkidu-like figure on
Indus Seal.
(Mohenjodaro. Marshall :No.357.
Kosambi 1965 :Pl.48)**

Mesopotamian and Indus Parallels

- 3.5 Kosambi draws parallels between the Babylonian legends and the Indus pictorial motifs on seals depicting characters looking like Gilgamesh and Enkidu (Figs. 3.1 & 3.2). According to him, the parallels between Vedic Urvaśī and Ushas, and the Mesopotamian Ishtar-Inanna is “unquestioned” (Kosambi 1962 : p.67). However, no narrative texts have survived from the Indus Civilisation to give us such wealth of information as found in the cuneiform inscriptions. We can only go by the broad parallelisms between the Citadel Mound, the Great Bath and the Dancing Girls of the Indus Civilisation, on the one hand, and on the other, the Mesopotamian Ziggurat tower, Inanna and Ishtar, the great goddesses of love, of Heaven and Earth, of Morning and Evening Star, and the troops of hierodules performing sex acts as fertility rites sanctified by hoary tradition. But we are not completely in the dark, if we regard similar legends in the *Ṛigvēda* (*RV*) and later Sanskrit literature as evidence for possible survivals from the Indus Age as pointed out by Kosambi in his books (1956, 1962 & 1965). The earliest evidence from the *RV* is summarised in the next Section.

IV. Indo-Aryan Parallels

Apsaras : the celestial water nymph

- 4.1 The earliest conception of the *apsaras* ('moving in the waters') in the *RV* is that of a celestial nymph. In later Vedic literature, the *apsaras* is connected with the earth where she dwells in lakes and rivers, and still later, on the fig trees. The only *apsaras* mentioned by name in the *RV* is *Urvaśī*, connected with her dialogue with *Purūravas* and the birth of *Vasishṭha*. There is also evidence which can be gathered from descriptions in the *RV* to classify a few more semi-divine beings with the *apsaras*, especially *Ushas*, the goddess of dawn, *Apyā yōshā* 'water damsel' and *Iḷā*, the mother of *Purūravas*. The *Atharva Vēda (AV)* (which has preserved more pre-Aryan elements than the *RV*), and later Vedic and Sanskrit literature mention the names of large numbers of *Apsaras*. They were essentially unattached and free celestial nymphs who occasionally descended on the earth to form temporary unions with rishis or kings, as illustrated by the stories of *Urvaśī* and *Purūravas*, *Mēnakā* and *Viśvāmitra*. As *Kosambi (1962: p.72)* points out, neither the lotus pond nor the *apsaras* could be Aryan in origin. The *RV* tells of the conflict between *Ushas* and *Indra*, hinting at her non-Aryan origin. The legends of celestial *apsaras* and their dalliance with human beings, occurring already in the *RV* and increasingly in later literature, may be interpreted as the survival and progressive re-emergence of the pre-Aryan and Non-Aryan cults of the Mother Goddess and her attendant deities. As we shall see presently, the constant association of the *apsaras* with the waters and celestial light in Vedic imagery provides the clues to connect them with the FISH signs of the Indus script. (See Paras 6.2 & 6.3).

Gandharva : The male consort of Apsaras

- 4.2 *Gandharva*, the male consort of the *apsaras*, is also associated with the waters and celestial light. The only *gandharva* mentioned by name in the *RV* is *Viśvāvasu*, 'possessing all goods'. As in the case of *Ushas*, *Indra* is hostile also to the *gandharva* indicating the latter's Non-Aryan origin. 'Gandharva in the waters' and *Apyā yōshā*, 'the aqueous nymph' are the parents of *Yama* and *Yamī*, the twins. *Gandharva* is connected with the wedding ceremony. The *AV* describes the

gandharva as ‘shaggy’ and to have half-animal forms. This reminds one of the Babylonian Enkidu and similar representations on the Indus seals and sealings. *Gandharva* is derived from *gandha* ‘fragrance’, which, as we shall see presently, provides the clue to his Dravidian origin. (See Para 6.53).

V. Dravidian Parallels

Ara-makaḷir

- 5.1 The earliest references to *ara-makaḷir* ‘divine damsels’ occur in the Caṅkam anthologies compiled in the early centuries C.E., but containing much older oral traditions. There are no individual names or specific myths associated with the divine damsels at the earliest stage. The information about them is mainly gathered from the attributes preceding the expression *ara-makaḷir* (mostly occurring in the plural). They hailed from the sky (*vāṇ*); they dwelt on the mountains (*varai*) and sported in the mountain streams (*aruvi*); they were connected with the fearsome deity *Cūr*. They were not associated with temples or temple-tanks, but only with groves and natural pools. They were quite distinct from the class of *parattai* ‘harlot’, a familiar institution in the Caṅkam Age. We can draw two broad inferences about the *ara-makaḷir* from the limited information available in the Caṅkam texts. They were regarded as mythical, semi-divine beings and were most probably associated with serpent worship as indicated by the constant reference to *ara* ‘serpent’ (glossed as ‘divine’ conventionally, but without any etymological basis).
- 5.2 It is likely that by the time the Caṅkam poems were composed, the Sanskritic tradition of the *apsaras* was also familiar in the South. In later Tamil literature of the early medieval period, the Sanskritic tradition becomes more dominant. The expression *nīr-ara-makaḷir* ‘water nymphs’ occurs (*Tamil Lexicon*). The names of individual apsaras known earlier from Sanskrit sources begin to appear in Tamil works : Arampai (*rambhā*), Uḷai (*ushas*), Ūrvaci (*urvaśī*), Mēṇakai (*mēnakā*) and Tilōttamai (*tilōttamā*). They were beautiful and accomplished in music and dance, and were mostly associated with the court of Indra.

Mīn-āṭci : the Fish Goddess of Madurai

- 5.3 The presiding deity of the temple at Madurai is known as Mīnākshi. The name (in Sanskrit) is traditionally translated as the ‘Fish-eyed (goddess)’. However, considering that the insignia of the Pāṇṭiya dynasty was *iṅgai kayal* ‘twin carp’, it appears that the name of the deity has been Sanskritised from Dravidian *mīṅ-āṭci* ‘rule by the Fish (goddess)’. Indeed, Mīnākshi is traditionally regarded as the Queen of the Pāṇṭiya kingdom. She is worshipped as *kanyā-kumārī* ‘the eternal virgin’ in the temple at the southernmost end of the land. She is also married to Sundara ‘the beautiful’, a form of Śiva, who, however, occupies quite a subordinate position in the temple of Mīnākshi. Their marriage is considered to be the ideal and is even now celebrated annually. The sacred marriage is the theme of a celebrated sculpture in the temple at Madurai (Fig.5.1). The legends of the eternal virgin and the sacred marriage are reminiscent of similar Mesopotamian myths and of the apsaras-gandharva legends in the Vedic tradition, briefly noticed in the earlier sections of the paper.



Fig.5.1 The sacred marriage of goddess Minakshi with Sundara. Madurai Temple. Nayak Period.

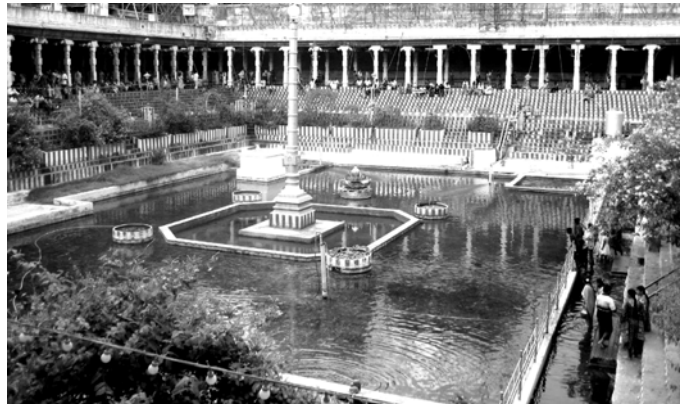

Fig.5.2 The Golden Lotus Pond. Minakshi Temple, Madurai. (cf. ‘Great Bath’ in Fig.2.1).

- 5.4 The sacred tank in the Minakshi Temple is known as *Pon-tāmarai-kuḷam* ‘the golden lotus pond’ (Fig.5.2). This legendary tank has its own claim to fame and was probably in existence even earlier than the temple as a natural lotus pond in a grove of Kadamba trees, as suggested by the name *Kaṭampa-vaṇam* for the site of the temple. According to tradition, the Golden Lotus Pond was the venue for

the meetings of the famous Tamil Caṅkam (Academy of poets), where new literary works were launched and evaluated.

The Twin Carp of the Pāṇṭiyar and the FISH Signs

5.5 The antiquity of the city of Madurai and the temple of the Fish Goddess with the Golden Lotus Pond attached to it, provides the necessary background to connect the insignia of the fish, especially the Twin Carp featured on Pāṇṭiya coins (Fig.5.4 to 5.6), with similar signs in the Indus Script (Fig 5.3). However, one may ask : Fish swim in all rivers including the Indus and the Vaigai; the Pāṇṭiyar could as well have chosen their ‘twin carp’ insignia from the fish occurring locally; why connect the Pāṇṭiya emblem with the Indus FISH ? The answer to this question lies deep in the proto-historic links between the Indus Civilisation and the Old Tamil culture, which can only be accounted for by the southern migration of the Dravidian clans including the Vēḷir and the Kōcar attested in the Caṅkam literature and supported by early historical tradition. (For details, see Mahadevan 1970, 1981, 1986b, 2009a&b and 2011).

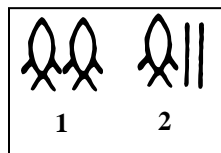

Fig.5.3 FISH signs (1&2) in the Indus Texts.

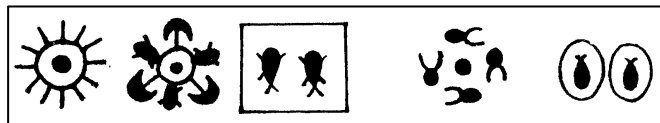

Fig.5.4 Twin Carp in Tank : Pāṇṭiya punch-marked silver coin. ca.2nd cent. B.C.E. (R. Krishnamurthy 1997: No.3).



Fig.5.5 FISH insignia on a Pāṇṭiya coin. ca.2nd cent. B.C.E. (A.A. Seetharaman 2004 : No.1.).



Fig.5.6 Twin Carp on a Pāṇṭiya coin. ca. 9th cent. C.E. (A.A. Seetharaman 2006 : No.1.).

The Temple Dancers of South India

- 5.6 The institution of Temple Dancers, so closely associated with the larger temples in South India in the medieval period, bears a remarkable resemblance to those of the Mesopotamian hierodules and the water nymphs associated with the sacred pools in the Indus cities (as postulated in this paper). There are no more fertility rites, and the focus shifts from the sacred pool to the temple; but the tradition of life-long dedication to the service of the deity by singing and dancing, and the myth that the temple dancers were ‘married’ to the deity, are elements which survived from the hoary past.
- 5.7 The best known instance is that of the four hundred dancing girls who were recruited from temples all over the Tamil country and attached to the magnificent ‘Big Temple’ (*Bṛihad-īśvaram*) built by the great Cōla emperor, Rājarāja (985-1014 C.E.), at Thanjavur. The emperor constructed special quarters called *taḷi-cēri* comprising three streets adjoining the temple with 400 houses allotted one each to the dancers. Each dancer was also given an annual maintenance allowance of hundred *kalam*s of paddy from one *vēli* of land assigned to the temple (*kalam* : 29 kg; *vēli* : 2.67 hectares). The dancing girls were collectively called *taḷi-cēri-peṇṭir* ‘women of the quarters in the temple’. The inscriptions engraved on the walls of the Big Temple record meticulously the names of the four hundred dancers, the streets and door numbers of their residences, and the original temples from where they were relocated. Their specific duties are not mentioned; but there is no doubt that these included mainly singing and dancing in the temple as made clear from the beautiful frescos painted on the walls of the *sanctum sanctorum* of the temple (Fig.5.7). Provision was also made for the appointment of supporting male staff including dance masters, musicians and players on musical instruments. (For details, See V. Mahadevan 2009: pp.293-331).



Fig.5.7 Dancing Girl.
Fresco. Big Temple,
Thanjavur. 11th cent. C.E.



Fig.5.8 Dancing Girl.
Cōla Copper Coin.
11th cent. C.E.
(A.A.Seetharaman 2008)



Fig.5.9 Dancing Girl.
Hoysalesvara Temple,
Halebid. 12th cent. C.E.

- 5.8 The temple dancers, well educated and highly accomplished in singing and dancing, had high social status as illustrated by an incident recorded in an inscription dated 1030 C.E. on the walls of the temple at Tiruvarur in Tamilnadu. A dancer named Paravai Naṅgaiyār attached to the temple was the beloved of Rajendra I (1014-1044 C.E.), Rajaraja's equally illustrious son and successor. The king seated her on his chariot and drove her to the temple in full public view. He endowed a perpetual lamp to be lit at the spot where he and his beloved dancer stood to worship the deity (Kudavayil Balasubramanian 1987: pp.110-114). Rajendra issued a copper coin featuring a dancing damsel, most probably to be identified with Paravai Naṅgaiyār (Arumuga Seetharaman 2008: p.18, No.2; Fig.5.8 in this paper.)
- 5.9 There is inscriptional and sculptural evidence from the medieval period that the larger temples in the Dravidian South had similar establishments of dancing girls and supporting staff, though on a more modest scale (Fig.5.9). The collapse of the traditional monarchies and impoverishment of the temples of South India in the late medieval period led to the degradation of the institution of the temple dancers. The *dēva-dāsī* (Skt.) or *tēvar-aṭiyār* (Ta.) literally 'servants of god' turned into common prostitutes. Agitation by social reformers in modern times led to the final abolition by law of the *dēva-dāsī* system.

Towards Resolution of a Paradox

- 5.10 Kosambi noticed the paradox posed by the complete absence of temples and hetaerae-hierodule institutions in the Vedic Civilisation and wondered about the source of the mother goddess cults, temples and institutions of temple dancers in the 'least Aryanised parts of India', which so closely resembled the Mesopotamian proto-types. He noted the pre-Aryan and non-Aryan origin of Agastya and his penetration to the South, but concluded that 'only intensive and systematic archaeology can decide' such issues (Kosambi 1962: pp.76, 81). While not disagreeing with him on this point, I suggest a supplementary route: ideographic interpretation of the Indus texts in the light of bilingual parallels from Indo-Aryan and Dravidian sources, and re-visiting the migration legends in the Old Tamil poems which appear to have preserved the memories of a distant past long anterior to the Caṅkam Age (Mahadevan 1970, 1986b, 2009a). Such a study would confirm that the proximate source for the cults of mother goddesses and temple dancers in medieval south India is the Indus Civilisation which had similar institutions. (See Section VI.)

VI. Interpretation of the FISH Signs

Methodology

- 6.1 At the outset I may point out that ideographic interpretations are based on broad and general meanings of the signs and may not necessarily bring out the exact phonetic values, especially of the included vowels in the roots and root-extensions forming the stems. But I do believe that the following interpretations correctly identify the basic Dravidian roots. In favourable circumstances, that is, when loanwords and/or the corresponding loan translations from Dr.>IA are found in appropriate contexts, the phonetic values of the roots and even stems would receive confirmation. While loanwords can be recognised more or less easily from phonetic similarities, loan translations are harder to spot, especially if they relate to universal concepts present in all cultures. However, incorrect loan translations with too literal or unintended meanings or from the wrong homophones produce strange, unusual or meaningless expressions, generally sought to be explained by equally bizarre myths and folk etymologies. These are the tell-tale clues to the real significance and approximate phonetic shape of the original expressions. This methodology is different from ‘decipherment’ which seeks to discover the exact phonetic values of the signs of an unknown script. According to me, ideographic interpretation based on multiple bilingual parallels is the only feasible course for understanding the largely logographic Indus Script in the absence of bilingual texts or longer narratives.

While interpreting the Indus Script in the light of later Indian historical tradition, one has to be on the lookout for layers as well as divergent streams of parallelisms resulting from three major variables :

- (a) Change in language (Early Dr. > IA > Later Dr.);
- (b) Evolution due to great time-depth (four millennia);
- (c) The vast continental size and diversity of South Asia.

I maintain that such parallels are not inconsistent with one another. On the contrary, they serve to strengthen the web of circumstantial evidence furnished by the multiple bilingual parallels. These are of course from later times, but can be shown to be derived ultimately from the ideograms of the Indus Script, which can then be interpreted in the light of the later evidence.

The basic or plain FISH Sign : Dravidian Interpretation



6.2 The ‘plain’ FISH sign is the basic element which identifies the whole group (Fig.1.1A). The basic FISH sign is interpreted in Fig.6.1.

Sign	Pictorial Identification	Dravidian Equivalent (literal)	Phonetic value (by rebus)	Intended meaning
	FISH	<i>mīṅ</i> ‘fish’ (DEDR 4885)	<i>miṅ</i> ‘to shine’ (DEDR 4876)	‘water nymph’ (‘who shines/ glitters’ and ‘connected with the waters’)

Fig.6.1 Interpretation of the basic FISH sign.

Two layers of meaning can be discerned in the suggested equation. The FISH is an ideogram for a nymph who is ‘shining’ (*miṅ*) and is also associated with the ‘waters’ like a fish (*mīṅ*). The basic Dr. root is *miṅ* ‘to shine, glitter, flash’ (DEDR 4876). The extended stems may have varying vowels and additions.

(e.g.) *miṅi* as in *miṅ-miṅi* ‘firefly (which glitters)’;

miṅukki (< *miṅukku*) ‘one who displays herself ostentatiously’;

miṅṅal ‘lightning’;

mēṅi ‘body, shape, colour, beauty’ (DEDR 5099), employed as a honorific for deity or eminent person. One of the nuances of the expression is ‘(bare) body’ .

Fish sign : Indo-Aryan Parallels



6.3 The equivalent expression in IA, *apsaras*, retains both associations. The prefixed *ap-* indicates her connection with the ‘waters’. The legends (of Ushas and Urvaśī in the *RV*) associate them with celestial light. However, while the *apsaras* was a mythical, semi-divine figure in the Indo-Aryan tradition, the Indus ‘water nymph’ was a real person, a priestess or hierodule attached to the sacred pool of the temple.

The cognates of *miṇ*, especially as in Ta. *miṇukku*, Ma. *minnuka*, *minukka*, Tulu *meṇaku* and Te. *miṇuku* etc., suggest that IA *mēnakā*, name of an apsaras, is a loanword from Dravidian with the meaning ‘one who shines or glitters’. Mēnakā was no ordinary apsaras. She enticed Viśvāmitra and gave birth to Śakuntalā, the mother of Bharata, the eponymous ancestor of the most famous Aryan clan, the Bharatas. I suggest that *Dr. miṇ- / miṇuk- / meṇak-* (>IA *mēnakā*) was the generic name of the water nymphs in the Indus Age.

NUMBER + FISH pairs : *gaṇas* of water nymphs

6.4 Only the basic FISH sign forms pairs with preceding numerals 3 to 7 (with the exception of 5, an omission which remains inexplicable). (See Fig.1.6, 3rd row.) The occurrence of ARROW and JAR suffixes of the singular number after the NUMBER + FISH pairs indicates that the numerals are ordinals to be read ‘third, fourth’ etc., and not cardinal numbers, ‘three, four’ etc. See the following examples (Fig.6.2).

		‘water nymph of the Third (Group)’ (masc./fem.)
		‘water nymph of the Fourth (Group)’ (masc./fem.)
		‘water nymph of the Sixth (Group)’ (masc./fem.)
		‘water nymphs of the Third (Group)’ (epicene pl.)
		‘water nymph of the Seventh (Group)’ (without gender suffix)

Fig.6.2 Interpretation of NUMBER + FISH signs

This pattern suggests that water nymphs, both women and men, were organised into numbered formations to perform various duties assigned to them. The FISH-ARROW pair represents the female nymph, and the FISH-JAR the male nymph, who were identified respectively as the *apsaras* and the *gandharva* in later Indo-Aryan tradition.

cf.Skt. *gaṇa* ‘flock, troop, tribe, class’ etc., from the root *gaṇ* ‘to count, enumerate’. In later literature, the apsarases and gandharvas are referred together as *gaṇas*:

cf. *apsarāṇām gaṇāḥ*; *gandharva-apsarāṇām gaṇa-saṁghāḥ* (*Mbh. Index*).

The expression *gaṇa* appears to be the source of the later appellation *gaṇikā* ‘courtesan’.

Fish Clusters : Composite Titles of Water Nymphs

6.5 A unique feature of the FISH signs is their tendency to form clusters, often as pairs, and rarely as triplets also. This pattern has fascinated – and baffled – scholars from the days of Hunter posing problems in interpretation. While the scope of the present paper will not allow a complete statistical analysis, I shall summarise the main features and attempt to interpret them consistent with the data. (For recent statistical tabulations and analysis based on the ASI Concordance 1977, See Nisha Yadav 2008 and G.Sundar et al 2008-09.)

(i) The clusters are always combinations of different FISH signs. The only exception is the pair AA with doubling of the basic FISH sign. This pair may perhaps be considered as an alternative way of writing the following modified FISH sign (Fig.1.1.G).

$$\begin{array}{c} \text{Two fish} \\ \text{Two fish} = \text{‘twin fish’} \end{array}$$

(ii) Leaving aside the exception explained above, the 5 FISH signs (in Fig.1.1 A-E, treating F&G as special forms of A) can form in theory 20 non-repeating pairs. Remarkably enough, 16 of the 20 possible pairs are actually attested in the Indus texts (ASI Concordance 1977). It seems therefore reasonable to infer that the absence of the other 4 pairs is merely due to the incomplete nature of the record. The general pattern seems to be that the FISH signs can occur in any non-repeating combination.

(iii) The ARROW sign, interpreted as the feminine singular suffix when attached to the FISH signs, is found after single, double or triple fish sequences. See examples (Fig.6.3).

2047	↑	⌘		
4285	↑	⌘	⌘̂	
3074	↑	⌘	⌘	⌘̂

**Fig.6.3 FISH clusters with ARROW suffix
(ASI Concordance 1977)**

- (iv) The evidence indicates that each water nymph had a name or composite title comprising one, two or three segments (attributes/epithets/titles) identified by the plain FISH plus semantic elements attached to the modified FISH signs.
- (v) Even though the FISH signs occur in very similar contexts, there are still some perceptible differences in their distribution pattern. Formal textual analysis and the linguistic interpretations suggested in this study indicate that the modified FISH signs can be classified into three sub-groups (Fig. 6.4).

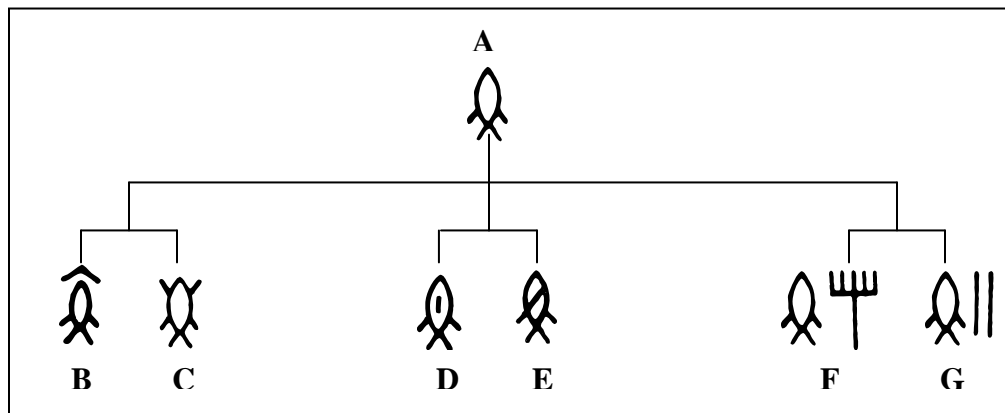



Fig.6.4 Classification of Modified FISH Signs

- (vi) The plain FISH (Fig.6.4A) is ‘basic’ from graphic and semantic angles. It is the basic building block for the modified FISH signs. It is also the basic generic name for the water nymphs symbolised by the FISH signs (see Para 6.3). An important feature of the sign is that it serves somewhat like a ‘determinative’ or visual cue (like capital letters in proper names in English) and was most probably not actually pronounced when occurring as part of the modified FISH signs. This suggestion helps to resolve a major problem in ‘reading’ the repetitive FISH signs in a cluster. I suggest that even in the text

with triple FISH signs (in Fig.6.3), the basic FISH sign in the final position may be a ‘spelling out’ and not actually pronounced.

Modified FISH Signs B&C : Dravidian Interpretation 

6.6 These two modified FISH signs (Fig. 6.4 B & C) occur with high frequency forming a closely related pair with similar distributional patterns in the Indus texts. One of the two modified FISH signs has an inverted V-like mark above, conventionally described as the ‘roof’; the other modified FISH sign is marked by ‘rays’ radiating outwards. (See especially the variant ) The modifying elements act as the semantic components as in the case of all modified FISH signs. I interpret the roof-like element as the ‘sky’ (‘roof of the Earth’) and the ‘rays’ to mean ‘twinkling’. Accordingly, the pair of modified FISH signs is interpreted as follows (Fig. 6.5).



SIGN	Pictorial identification	Ideographic interpretation	Dravidian equivalent	Intended meaning
	FISH with ‘roof’	‘sky’	<i>vāṇ</i> (<i>miṇ-</i>)	celestial (water nymph)
	FISH with ‘rays’	‘twinkling’	<i>cim-ay</i> (<i>miṇ-</i>)	celestial (water nymph)

Fig.6.5 Interpretation of Modified Fish Signs (in Fig. 6.4 B&C).

Celestial water nymph (of the ‘sky’) 

6.7 The selected root *vāṇ* ‘sky’ has cognates in many Dravidian languages :

(e.g.) Ta. *vāṇ*; Ma. *vān*; Ka. *bān*; Tu. *bāna*; Go. *vāna* (DEDR 5381).

The expression *vāṇ-* has the meanings ‘celestial, heaven’ in Old Tamil usage :

cf. *vāṇ* ‘sky’ (*Aka.* 1:16; *Kurun.* 102:3);

vāṇam ‘sky’ (as contrasted with earth) (*Kurun.* 130:1);

vāṇavar ‘celestial beings, *dēva-s*’ (*Cilap.* 10:158);

vāṇ-ara-makalir ‘celestial damsels’ (*Naṟr.* 356 :4);

vāṇava-makalir ‘celestial damsels’ (*Matur.* 582);

vāṇ-koti ‘streak of lightning’ (*Cilap.* 1:24);

vāṇavan ‘Cēra King’ (*Aka.* 33:14); (see Para 6.9 below).

Celestial water nymph ('who shines / twinkles') 

6.8 The selected root *cim-ay* 'to glitter, shine, twinkle,' has cognates in many Dravidian languages :

(e.g.) Ta. *imai* 'to glitter, shine, twinkle' ; Ma. *imekka* 'to twinkle' ;
Ka. *cimuṭu* 'to twinkle' ; Koḍ. *cimm-* 'to twinkle' (DEDR 2545).

The expression *imai-* (with the loss of the initial palatal sound *c-*) has the meanings 'twinkling, celestial' in Old Tamil usage :

cf. *imaikkum* 'twinkling' (*Puṛa.* 270.1; *Kuṛun.* 150:2) ;
imaippa 'twinkling' (*Kuṛun.* 314 :2) ;
imaiyōr 'celestials' (*Tol. Poruḷ.* 248) ;
imaiyavar 'celestial beings' (*Perumpāṇ.* 429) ;
emayavaṇ (< *imaiyavaṇ*) 'a personal name', (Tamil-Brāhmī inscription, ca. 2nd cent. B.C.E.) (*Tamiḷ-Pirāmi Kalvetṭukaḷ* 2006, No. 2:2).

Ima(i)yavar- and Vāṇavar- : Cēra Titles derived from the Indus Civilisation

6.9 I propose that the plural forms of these two modified FISH signs are the source of the Cēra titles of the Caṅkam Age (Fig. 6.6).



Sign	Dr. equivalent	Cēra Titles of the Caṅkam Age
	<i>vāṇ(a) -ar</i> >	<i>vāṇavar</i> 'they of the celestial (lineage)'
	<i>cimay(a) -ar</i> >	<i>ima(i)yavar</i> 'they of the celestial (lineage)'

Fig.6.6 Indus origin of Cēra titles of the Caṅkam Age.

The Cēra kings of the Caṅkam Age sported the following pair of titles :

Ima(i)yavarampaṇ (*Patīṛ.* 2 col. ; *Cilap.* 26:23, 30:161) ;

Vāṇavarampaṇ (*Aka.* 45:17, 359:6, 389:16; *Puṛa.* 2:12; *Patīṛ.* 38:12, 58:12).

According to tradition, the titles signified that the Cēra kings had *imaya-* 'Himālaya mountain' or even *vāṇa-* 'sky' as the 'limit' (*varampu*) of their dominion. It has been shown by Mayilai Seeni Venkataswamy (1966 : pp.124-132) that these titles were adopted alternately by successive generations of the Cēra kings of the Caṅkam Age. He pointed out that the title *vāṇavaṇ* 'celestial being' was borne by the Cēra kings (*Aka.* 33:14) and that the expression *imaiyavar*

‘celestial beings’ is also attested (*Cilap.* 5:97). He suggested that the readings *imaya-varampan* and *vāna-varampan* are due to scribal error and the traditional meaning due to wrong segmentation. He proposed the revised readings *imaiyavar-anpan* and *vānavar-anpan*, both with the meaning ‘beloved of the gods’. He pointed out the similarity with the Mauryan title *dēvānampīya* ‘beloved of the gods’, which was also adopted by some Sinhala rulers of SriLanka. It is probable that the titles *imaiyavar* and *vānavar* were later expanded by the addition of the suffix *-anpan* ‘beloved’ in emulation of the dynastic title *dēvānampīya* ‘beloved of the gods’ sported by the Mauryan and SriLankan rulers.

The two modified FISH signs B&C with the literal meanings ‘sky’ and ‘twinkling’ respectively seem to have no specific survivals in Indo-Aryan, apparently because they were replaced in both senses by the all too common *dēva* (<*div*) suffixed almost universally to the names of gods as well as princes and other eminent personages. A similar development, but in the opposite direction with the apparent loss of the Dravidian equivalent of *gandharva*, is discussed later (Para.6.54).

Modified FISH Signs D&E : Dravidian Interpretation

6.10 It will be convenient to consider these two modified FISH signs (Fig.6.4 D&E) together as they form a contrasting pair. Both signs bear marks on their bodies. One of them is marked with a short, vertical stroke, rarely shown also as a dot (Fig. 6.7 : variants 1&2). The other is marked by a slanting stroke across the body, less frequently drawn horizontally (Fig. 6.7 : variants 3&4). Orientation of the strokes indicates the meanings of the two signs.

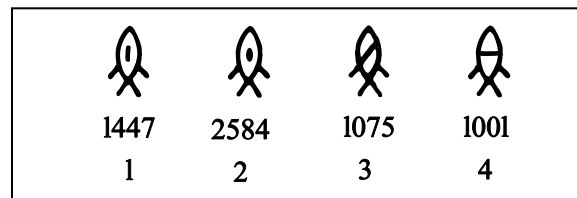

Fig.6.7 FISH Signs marked by vertical stroke / dot and slanted/ horizontal stroke (ASI Concordance 1977).

I interpret the vertical stroke as representing the ‘rising’ and the slanted stroke as the ‘setting’ (of the sun). The interpretation is based on West Asian parallels

(cf. Paras 3.1&3.2), Early Indo-Aryan parallels (cf. Para 4.1) and Dravidian parallels considered below.

Water Nymphs of Rising and Setting (Sun) 

6.11 The corresponding Dravidian etyma are given below (a & b):

- (a) Konḍa *sō-* ‘to come up (as sun and moon)’; Pe. *hō-* ‘to come out’; Mand. *ja-* ‘to rise (as sun)’; Kui *ho-* ‘to come out’; Kuwi *hōcali-* ‘to rise (as sun and moon)’; Kur. *cō’onā* ‘to rise in the air’ (DEDR 2867).
- (b) Ta. *cāy* ‘to incline, decline as a heavenly body’; *cāyvu* ‘slope, declivity’; *cāyppu* ‘slant’; Mand. *hē-, jē-* ‘to descend’; Kui *jāpa* ‘to descend’ (DEDR 2456).

The linguistic evidence points to the Early Dravidian roots :

- (a) *cō* ‘to rise (as a heavenly body)’;
- (b) *cāy* ‘to decline (as a heavenly body)’;

Combining the ideographic and linguistic evidence we arrive at the following interpretations (Fig.6.8).



Sign	Pictorial Identification	Dravidian Equivalent	Intended Meaning (Titles)	Old Tamil Survivals (Clans)
	Fish + vertical stroke	<i>cō-</i> (<i>miṇ-</i>)	water nymph of the Rising (Sun)	<i>ōy</i>
	Fish + slanted stroke	<i>cāy-</i> (<i>miṇ-</i>)	water nymph of the Setting (Sun)	<i>āy</i>

Fig.6.8 Interpretation of Modified FISH Signs (in Fig.6.4 D&E).

6.12 I suggest that water nymphs with these two titles were recruited from the Vēḷir clans in the Indus Age. The story of the southern migration of the ‘Eighteen Vēḷir’ clans led by Agastya from Dvārakā in Saurashtra to South India is attested in Old Tamil literature and well supported by later historical tradition. The best documented account of the migration is still *Vēḷir varalāru* by M. Raghavaiyengar (1907). I have extrapolated the data further back in time to connect the Vēḷir with the ruling classes of the Indus polity (Mahadevan 1970, 1986b & 2009a).

cf. *vēḷ* literally a ‘priest’, later appearing as the *Vēḷir* (plural) ‘chieftains’ in Old Tamil literature.

- 6.13 Judging from the ideography, it appears that the Rising (Sun) title had a higher rank than the Setting (Sun) title. However, the ratio of occurrence of vertical/slanted stroke-marked FISH signs is about 1:2.5. The marked difference in frequency may be accounted for by the supposition that nymphs with the lower ranked title were more numerous than those with the higher ranked title in the Indus society. However, the survivals in Indo-Aryan to be noticed below indicate greater importance to the higher ranked title.

Vēḷir clans in Old Tamil Society

- 6.14 When the Vēḷir migrated to South India at the end of the Indus Civilisation, they must have carried their earlier titles *cō* and *cāy* into pre-Old Tamil. By the time the Caṅkam poems were composed in the last centuries B.C.E., these titles had become clan names which were transformed into *ōy* - and *āy* respectively due to the loss of the initial palatal sound *c-*. Combining Old Tamil attestations with the linguistic evidence summarised above, we can derive the names of the Vēḷir clans as follows :

cō > *ōy* (singular) > *ōviyar* (plural);
cāy > *āy/āvi* (singular) > *āviyar* (plural).

The linguistic changes must have occurred not much earlier than the Caṅkam Age as proved by the presence of pairs of Tamil words with or without the initial palatal *c-* .

(e.g) *camai/amai* ‘to be made, constructed’ ;
camaṅ/amaṅ ‘Jaina religion’ etc.

It is interesting in this connection to compare a clan name in the Asokan edicts with the corresponding Old Tamil name :

satiyaputō: Name of a neighbouring ruler (Second Rock Edict of Asoka, Girnar);
atiyamāṅ : Name of a famous chieftain of the Caṅkam Age (*Pura.87-95*) ;
(*satiya* > *atiya*; *putō* : *makaṅ* > *māṅ*) (Burrow 1968: pp.158-159;
Mahadevan 2003:No.59).

I have discussed elsewhere recent epigraphic evidence that Prakrit names like *sata*, *sāta* and *satiya-* (all borrowed earlier from Dravidian) are the source of Old

Tamil names *Ataṅ*, *Ātaṅ* and *Atiyaṅ* respectively (Mahadevan 2003 : pp 588-589; 2009a).

Brief History of the Ōy > Ōviyar clan in the Tamil Country

- 6.15 The region included in South Arcot District in Tamilnadu was known in ancient times as Ōymāṅ nāṭu (*Cīrupāṅ*. col.). The chieftains who ruled over the region with Māvilaṅkai (modern Tindivanam) as their capital had names like Ōymāṅ Nalliyakkōṭaṅ (*Pura*. 176 col.), Ōymāṅ Nalliyātaṅ (*Pura*. 376 col.) and Ōymāṅ Villiyātaṅ (*Pura*. 379 col.). They were collectively known as the Ōviyar (*Cīrupāṅ*. 122). The whole of the long poem *Cīrupāṅ-āṟruppaṭai* (part of the collection of *Pattuppāṭṭu*) is on Ōymāṅ Nāṭṭu Nalliyakkōṭaṅ.

The port city in Ōymāṅ nāṭu was known as Cō (also as Cō-nakar or Cō-paṭṭinam) (*Nāṅmaṅi. kaṭavul*:2; *Cilap*. 6: 54-55, comm.; 17: 35.3). The city is referred to as ‘Sopatma’ in the *Periplus* providing us with valuable evidence for the survival of the name with the initial palatal *c-* at least up to the First Century C.E. The place has been identified with modern Markāṅam about 30 km. north of Pondicherry on the East Coast. It is also possible that the prefix *Cō-* in the personal names of some Caṅkam poets like Cō-kīraṅ-ār (*Narr*. 277 & 319), Cō-kuttaṅ-ār (*Narr*. 329 & 352) and Cō-kōvaṅ-ār (*Narr*. 365) refers to their clan name or native place. There is no direct evidence that the Ōy / Ōviyar belonged to the Vēḷir clan. However, the close similarity of the names *ōy* > *ōviyar* with *āy* / *āviyar* (who are known to belong to the Vēḷir clan) suggests this as a possibility. (For details on the Oviyar clan, see Durai Rangaswami 1960 : pp.281-295.)

The legend of Uḷai (< Skt. *ushas*), the Princess of the city of Cō (*Cilap*. 6 :54-55, comm.) , confirms the suggested bilingual parallelism between Dr.*cō* ‘to rise’ and IA *ushas* ‘goddess of dawn’. (Compare Figs.6.8 &6.9; see also Para 6.18 below.)

Brief History of the Āy > Āviyar clan in the Tamil Country

- 6.16 The Āy clan was more numerous and their names appear earlier and lasted longer than those of the Ōy clan in Old Tamil literature. The Āy-s ruled over the southernmost region of the Tamil country (parts of Tirunelveli and Kanyakumari districts in Tamil Nadu and South Kerala). Their capital was Āykuṭi near the Ceṅkōṭṭai Pass in the Western Ghats. Their territory included Cape Comorin and the Potiyil hill, the legendary abode of Agastya. Ptolemy, the Greek geographer

(130 C.E.), refers to ‘Aioi ’ ruling in this region. Several rulers of the Āy clan figure in the Caṅkam anthologies, among whom the most famous were Vēḷ Āy Aṅṭiraṅ (*Pura.* 127- 136 col.), Āy Eyiṅaṅ (*Aka.* 148, 181, 208 & 396), Vēḷ Āvi, the chieftain of Potiṅi or Āvi-naṅ-kuṭi (modern Paḷaṅi) (*Aka.* 61) and Vēḷ Evvi (*Pura.* 24) who ruled over the Miḷalai region (in modern Nagapattinam District). In the post-Caṅkam Era, the Āy-s of Āy-kuṭi were still powerful enough to issue copper plate grants in their own names claiming, among other things, that they belonged to the *Vṛishṇikula* (Paliyam Plates, 9th century C.E., *TAS*: I, p.187). For details on the Āy clan, see Durai Rangaswamy 1960:pp.281-289.

There is a solitary but interesting reference to *cāy-iṅa-tt-āṅ* ‘one who belongs to the Cāy clan’ in the Caṅkam anthologies (*Patir.* 60:12). However, the clan name Cāy was apparently forgotten in later times; the medieval commentary has translated the expression as ‘one in the company of beautiful women’, a meaning not supported by the context. This interpretation needs reconsideration in the light of the new evidence.

Water Nymphs of Rising and Setting (Sun) : Indo-Aryan Parallels

6.17 The importance of these two modified FISH signs in the Indus Age is reflected in the relatively larger number of Indo-Aryan parallels noticed below. We shall commence with the most important pair namely Ushas and Nakta, the Goddesses of Dawn and Night in the *RV* (Fig.6.9).





	The ‘Rising’ Nymph :	<i>Ushas</i> , ‘the Goddess of Dawn’.
	The ‘Setting’ Nymph :	<i>Nakta</i> , ‘the Goddess of Night’.
	The ‘Rising and Setting’ Nymphs :	<i>Ushāsā-Naktā</i> , ‘Goddesses of Dawn and Night’.
	The ‘Setting and Rising’ Nymphs :	<i>Nakt-ōshāsā</i> , ‘Goddesses of Night and Dawn’.

Fig.6.9 Modified FISH Signs as Goddesses of Dawn and Night.

Ushas : The Goddess of Dawn

- 6.18 The goddesses occupy a very subordinate position in the *RV* with the notable exception of Ushas, the ‘Goddess of Dawn’. The name *ushas* is derived from the root *vas* ‘to shine’ (cf. Dr. *miṅ* ‘to shine’). “Arraying herself in gay attire like a dancer, she displays her bosom. Like a maiden decked by her mother, she shows her form. Clothed in light, the maiden appears in the east and unveils her charms ... Rising resplendent as from a bath, showing her charms, she comes with light driving away the darkness” (*Vedic Mythology*: pp.46-47). The unusual imagery makes it clear that Ushas represents not merely the physical phenomenon of dawn, but is in fact an *apsaras*. As the Mesopotamian Inanna-Ishtar goddesses are associated with the morning and evening star, so is Vedic Ushas with the rising and setting of the Sun at Dawn and Night. Ushas, the goddess of Dawn, is inseparably associated with Night, as shown by her dual names in the *RV*, *Ushāsā-naktā* and *Nakt-ōshāsā*.

Nymph with staff : Rambhā, the *apsaras*

- 6.19 Rambhā, a celebrated *apsaras* known at least from the time of *Mbh.*, was considered to be the most beautiful dancer in Indra’s court. She was the wife of Nala-Kūbara and was carried off and violated by Rāvaṇa. The etymology of the name can be gathered from the following expressions (MW):

rambha: ‘staff’ (*RV*); a ‘bamboo’ (lexical);

rambhin: ‘one carrying a staff or stick’.

Thus we can interpret the FISH sign marked by the vertical stroke pictorially as the ‘nymph with staff or stick’ and equate her with Rambhā.

Talai-kōli of Tamil Tradition

- 6.20 Rambhā seems to have been more prominent in the medieval Tamil tradition, as *arampaiyar* (in the plural) becomes the generic name in Tamil for the *apsaras*. It is interesting that while *rambha* ‘bamboo’ is merely a lexical entry in Sanskrit, it is associated with the staff of eminence or distinction awarded to dancing girls in Tamil tradition. The most celebrated dancers in the temples of the Tamil country in the medieval period were awarded the title *talai-kōl* or *talai-kōli* which may be interpreted as ‘the Head (dancer) with a staff (of authority)’. There

is evidence that the Tamil tradition was much older. The Caṅkam anthologies (*Aka.*97:9-10; *Kurun.* 298:6) describe the *īrai-makaḷ* ‘divine damsel’, also known as *akavaṇ-makaḷ* or *vīrali* ‘singer, dancer’ as possessing a short staff (*ciṟu kōl*) made from specially selected bamboo (Kalaikkovan 2004:pp.13-26).

Tilōttamā : the apsaras with *tilaka*

- 6.21 The variant FISH sign marked with a dot (Fig.6.7.2) is the source of yet another legend of later times relating to Tilōttamā, the apsaras. The name is etymologically derived as follows (MW) :

tila ‘sesamum indicum ; a mole, a small particle’ ;

tilaka ‘ a freckle’, compared to a seasmum seed; a ‘mark on the forehead’.

The account in the *Mbh.* about Tilōttamā corroborates the etymology. According to the legend, Brahman caused Viśvakarman to make a celestial maiden (*apsaras*) from “small particles of every kind of gem, whence she was called Tilōttamā” (*Mbh. Index*). The allusions to a gem indicating that the apsaras was ‘glittering’, and to *tila* referring to a ‘small particle or mole’, furnish sufficient evidence to identify the name *tilōttamā* as derived ultimately from the FISH sign with the dot or mole on the body. cf. Ta.*māṇikkam* ‘ruby, brilliant gem’, the title awarded to accomplished Dancing Girls attached to the temples in the Tamil country (inscr.).

The legend of Tilōttamā in Indus Art

- 6.22 According to another legend in the *Mbh.*, Hiranyakaśipu, the asura, had two sons named Sunda and Upasunda. They were always together and shared with each other happiness as well as woe. They acquired immense power through their austerities and conquered the three worlds. They obtained a boon from Brahman that they would not be afraid of any one except of each other. In order to curb their power, Brahman sent Tilōttamā, the apsaras, to seduce them. Sunda and Upasunda fell in love with Tilōttamā and became jealous of each other. Then they fought over her and struck each other to death with their maces (*Mbh. Index*) or with uprooted trees according to another version. This legend appears to be a survival from the Indus Civilisation, as the story is featured on a sealing from Mohenjodaro (Fig. 6.10A) and also on a cylinder seal from Kalibangan (Fig.6.10B) .



Fig.6.10A : Terracotta sealing. Mohenjodaro. (Mackay : XC. 23). (CISI-I : M-478). Pictorial motif recalling the legend of Tilōttamā.



Fig.6.10B : Impression from a cylinder seal. Kalibangan. (CISI-I : K-65). Pictorial motif recalling the legend of Tilōttamā.

The rectangular pottery sealing from Mohenjodaro shows two men, each armed with an uprooted tree, fighting over a woman standing in the middle with her arms extended as if to ward them off from her. The cylinder seal from Kalibangan has an exactly similar scene except that the two men are fighting with spears over the woman standing in the middle. There can hardly be any doubt that both the seal and the sealing depict the legend current in the Indus Civilisation, which survived in later Sanskrit literature as the story of Sunda and Upasunda, the asuras, fighting over Tilōttamā, the apsaras.

Tilōttamā and her 'marriage badge' (Dr. *poṭṭu*)

6.23 The derivation of the name *tilōttamā* from *tila* 'particle' and '*tilaka*' 'dot on the forehead' brings out a very interesting parallel from Tamil tradition.

cf. *poṭṭu* 'round mark (red, white or black) worn on the forehead' (DEDR 4492); *poṭṭu kaṭṭutal* 'ceremony of dedicating a dancing girl to a temple by tying the marriage badge around her neck' (*Tamil Lexicon*).

The dancing girl with the *poṭṭu* badge around her neck was considered to have been married to the presiding deity of the temple. This practice may be compared with the Mesopotamian *hieros gamos* 'sacred marriage' (Para 3.1), and the 'sacred marriage' of the Virgin Goddess (*kanyā kumārī* = *Mīnākshī*) to the god in the temple at Madurai (Para 5.3). The significance of the necklace stringing together three beads worn by the celebrated bronze dancing girl of Mohenjodaro (Fig.2.4a) now stands revealed.

The Fish Incarnation of Vishṇu and the Indus FISH Symbolism



- 6.24 The Fish is traditionally regarded as the first incarnation of Vishṇu (*matsya-avatāra*). It is therefore quite significant that several aspects of Vishṇu appear to be connected with the Fish symbolism of the Indus Civilisation. We shall notice briefly some of these links in this study.

Lakshmī, the ‘marked one’

- 6.25 Rambhā, the apsaras, is sometimes regarded as a form of Lakshmī (MW). The link between them in the present context becomes clear from the following etymology.

laksha ‘a mark, symbol’ ; *lakshana* ‘a mark, sign or symbol ; stroke or line’ (MW). *lakshmi* ‘a mark, sign, token’ (RV).

Thus we can identify the FISH sign marked with a short vertical stroke or dot (Fig. 6.7, variants 1&2) as representing *Lakshmī*, ‘the consort of Vishṇu’.

The ‘Sacred mole’ of Vishṇu

- 6.26 Goddess Lakshmī is said to reside in the chest of Vishṇu. Vishṇu has a mole known as *śrīvatsa* on his chest. As mentioned above, *lakshmi* has the literal meaning ‘mark, sign’. It would thus appear that the Indus FISH sign, marked boldly with a mole-like spot on the body, is the ultimate source of *śrīvatsa*, the ‘sacred mole’ of Vishṇu.

cf. Ta. *maṛu* ‘sign, symbol, mole, freckle, wart’ (*Tamil Lexicon*).

Tiru-maṛu-māṛpaṇ ‘Vishṇu having the sacred mole on his breast’ (*Kali*.104:10).

The ‘Three abodes’ of Vishṇu symbolised by the FISH Signs

- 6.27 Vishṇu’s ‘three abodes’ are generally regarded as referring to the ‘rising, culminating and setting’ of the sun. The interpretation of the modified FISH signs as representing the rising, shining (in the sky) and setting (of the sun), leads to an interesting parallelism with the ‘three abodes of Vishṇu’ (schematically shown in Fig. 6.11).

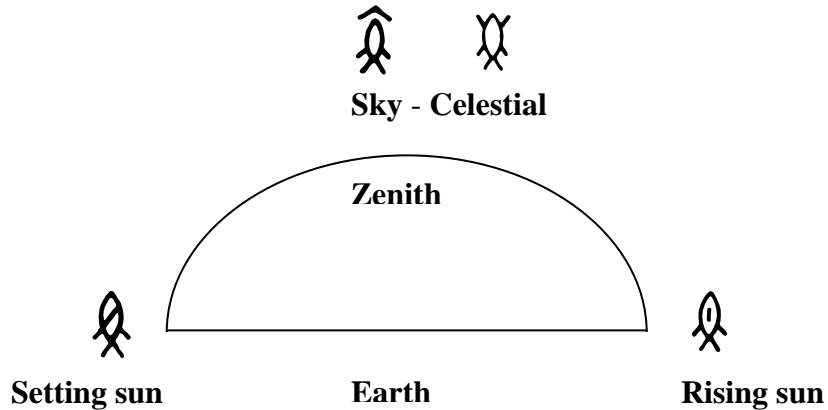

Fig.6.11 Indus FISH Signs marking the ‘three abodes’ of Vishṇu

The ‘three postures’ of Vishṇu symbolised by the FISH signs

6.28 The Vaikhānasa tradition prescribes iconic representation of Vishṇu in three postures namely, standing, seated and reclining :

sthānaka (Ta. *ninra*) ; *āsana* (Ta. *irunta*) ; *śayana* (Ta. *kiṭanta*).

cf. *ninrāṇ iruntāṇ kiṭantāṇ* ‘one who remained standing, seated or reclining’ (*Nālāyira*. Poykai. *Mutal*: 77. See also R.Champakalakshmi 1981: pp.37-39). These forms correspond exactly to the three positions suggested by the modified FISH signs (Fig.6.12).

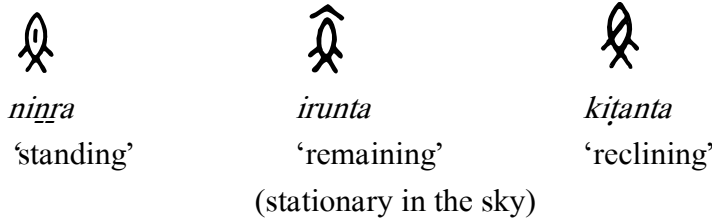



Fig.6.12 Interpreting modified FISH Signs as ‘three postures’ of Vishṇu.

The Great Water Nymph : Dravidian Interpretation

6.29 This frequent pair of signs (Fig.6.4 F) comprises the basic FISH sign preceded by a qualifying sign. The signs may be interpreted in Dravidian as follows.

Sign 

The sign functions as an attribute and is pictorially identical with the cuneiform sign *gal* ‘great’ (Hunter 1934: App.II, No.47). The meaning has been assumed by several other scholars to be broadly similar in the Indus texts where it suits the context (Heras 1953: p.76; Gurov in *Proto-Indica 1968*: pp.44-45; Mahadevan 1970: pp.195-197). The corresponding Dr. root has the following range of literal and figurative meanings :

nīl̄ ‘long, tall, wide, extensive’ (literal) ;
 ‘great, lofty , all-pervading’ (figurative) DEDR 3692.

The word *nīl̄* occurs in Old Tamil.

cf. *nīl̄ kuṭi* ‘great lineage’ (*Pura* 71 : 17)
nīl̄ ‘great’ (*Piṅkala*.)

Thus we can equate the modified FISH sign (in Fig.6.4F) with Dr.*nīl̄ min̄* ‘the great shining one’ and interpret the expression as the ‘great water nymph’ to distinguish her from the ordinary water nymphs represented by the ‘plain’ FISH sign (Fig 6.13).

Modified Fish Sign	Pictorial Identification	Dravidian Equivalent	Intended Meaning
	RAKE + FISH	<i>nīl̄ (min̄)</i> ‘great shining one’	great water nymph

Fig.6.13 Interpretation of Modified FISH sign (in Fig. 6.4 F).

6.30 *Urvaśī* , the Great Water Nymph : Indo-Aryan Parallel 

The modified FISH sign is interpreted in Dravidian as *nīl̄(min̄)* literally, ‘wide (shining) one’, but with the intended meaning ‘great water nymph’. This expression appears to be the ultimate source of the following loan translation in the *RV*: *uru* ‘wide, broad, extended’ (literal);

‘great, excellent’ (figurative);
 -*vaśī* ‘ all-pervading’ from *aś* ‘to pervade’.

Hence, *urvaśī* ‘widely extending’ , name of an apsaras in the *RV*(MW).

I suggest that *urvaśī* derived from Dr.*nīl* ‘wide > great’, served as the title of a superior class of apsarases, the Indo-Aryan equivalent of the water nymphs in the Indus Civilisation. This suggestion is corroborated by several elements connected with *Urvaśī*, the only apsarases to be named in the *RV*. She is specifically called an apsarases in the legend where she is described as the mother of *Vasishṭha* who is clad in lightning and surrounded by apsarases (*RV* 7.33). *Urvaśī* is described as ‘aqueous’ (*apyā*) and also compared with ‘a flash of falling lightning’ in her famous dialogue with *Purūravas*, son of *Ilā*, herself an apsarases (*RV* 10.95). The story is elaborated in *ŚBr.* where *Urvaśī*, after leaving *Purūravas*, is residing in a lotus pond where she is found swimming with other apsarases. *Urvaśī* is once invoked with the streams (*RV* 5.41.19). The constant association of *Urvaśī* with the waters and lightning indicates that the name is ultimately derived from Dr.*nīl* *miṅ* of the Indus texts.

Dravidian Origin of *Ilā*, the apsarases

- 6.31 *Ilā*, the mother of *Purūravas*, was herself an apsarases. Her name, spelt with the retroflex *l*, suggests a Dravidian origin. The possibility is briefly explored here. In the *Vaikhānasa* tradition, *Nīlā* is mentioned as a consort of *Vishṇu*. Many of the *Vishṇu* temples in the Tamil country have separate shrines for *Nīlā-dēvī*, in addition to those of *Śrīdēvī* and *Bhūdēvī*. I suggest that Dr.*nīl* ‘tall, wide, great’ was borrowed into Indo-Aryan as a loanword in the literal sense of ‘wide’, a well-known attribute (*uru*) of *Vishṇu*, and in the instant case, transformed from an attribute to being the consort of *Vishṇu* as *Nīlā*. It is also likely that *Nīlā* is another aspect of *Bhūdēvī*; cf. *urvī* (fem.) ‘earth (as the wide one)”; Ta.*nīl* *nilam* ‘wide earth’ and Skt. *pṛithvī* ‘wide(earth)’.

One of the phonological developments, early and wide-spread among the Dravidian languages, is the occasional elision of the initial *n*- as in Ta.*nīr* ‘water’ > *īram* ‘moisture’. According to *Zvelebil* (1970: pp.132-133), the *n*-zero alternation may have been present in the parent Dravidian speech itself, since it occurs widely scattered throughout the entire family.

In the light of the linguistic evidence summarised above, I propose the derivation of *Ilā* (apsarases) from *Nīlā* (goddess). An interesting conclusion which emerges from this study is that *Urvaśī* (lit., the ‘wide one’) is both the mother and lover of *Purūravas*, as both names are derived from the Indus –Dravidian  *nīl*(*miṅ*) ‘the great nymph’. *Urvaśī* is connected with *Ilā* as well as *Bṛihad-divā*

(*RV* 4.41.19). All the three are apsaras. Their names have the same meaning which can ultimately be derived from Indus-Dravidian *nīl* (*min*) ‘wide / great, shining water nymph’. (See Fig.6.13.) According to the *Mbh.*, Ilā was both the father and mother of Purūravas. This tradition may be traced back to the Indus polity in which  *nīl* (*min*) ‘the great nymph’ (corresponding to Urvaśī) is mostly female, but may also be a male nymph. (See Fig 1.15).

The Twin Water Nymphs : Dravidian Interpretation

6.32 This modified FISH sign (Fig. 6.4 G) occurs almost as frequently as ‘the great water nymph’ (taking the singular and plural forms into account). The attribute, a pair of tall parallel lines, is the semantic element which distinguishes these nymphs from the others in the group. The paired lines suggest ‘duality’ which becomes the source of many myths with some twin entities at their core. However, the occurrence of the paired lines before the ideogram for ‘water nymph’ would restrict our choice to the parallels discussed below.

The evidence indicates that the ‘two tall lines’ have to be understood not as ‘two’ or ‘second’, but as ‘pair or twin’.

cf. Ta. *iṇai* ‘pair, couple’, (DEDR 457) as in *iṇai-kayal* ‘twin carp’, the insignia of the Pāṇṭiyar, at least from the Caṅkam Age (cf. Paras. 5.3-5.5 and Figs.5.4 & 5.6); *iraṇai* ‘couple, pair’ (DEDR 474).

‘Nymphs of Heaven and Earth’ : An Indo-Aryan Parallel

6.33 I suggest that the pair of parallel lines were originally horizontal and had to be turned vertical to save space on the seals, as in the case of the FISH signs.

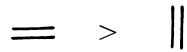

The paired lines can then be interpreted literally as the ‘sky’ (upper line) and ‘earth’ (lower line), the ‘upper and lower spaces’. The title ‘Nymph of Heaven and Earth’ is reminiscent of a similar title of the Sumerian goddess of love, Inanna (see Para 3.1 above).

In the *RV*, the pair *dyāvā-prithivī* ‘Heaven and Earth’ is the most important among the dual divinities and is almost always mentioned together. The conception of Heaven (the father) and Earth (the mother), as the universal parents, is said to go back to the Indo-European period. However, conjoint worship of Heaven and Earth is known to all primitive societies. The Sumerian

title mentioned above is probably pre-Indo-European. From the standpoint of this study, it is significant that Heaven and Earth are also very often called in the *RV*, *rōdasī* (in feminine dual number), regarded as ‘twins’. The expression *rōdasī* (in the singular) is also the name for ‘lightning’ in the *RV*. I suggest that the conception of *rōdasī* as ‘lightning’ and ‘sisters’ represents the Indus tradition, occurring almost as prominently as *dyāvā pṛithivī* in the *RV*.

Yama and Yamī, the ‘Twin Nymphs’ : Another Indo-Aryan Parallel 

- 6.34 The expression *yama* means literally ‘twin-born, twin or forming a pair’ (MW). Yama and his sister Yamī are the primeval twins born to the ‘gandharva in the waters’ and Apyā yōshā, the ‘aqueous (water) nymph’ (*RV*10.10.4). Yama’s father was Vivasvat, whose name literally means ‘brilliant or shining’. It is noteworthy that this expression is derived from the same root as *ushas*, ‘the dawn’. Yama’s mother was Saranyū also generally identified with Ushas, the ‘goddess of Dawn’. Yama is surrounded in his abode with songs and the sound of the flute (*RV* 10.135.7). These details are sufficient to show that Yama and his twin sister Yamī belonged originally to the class of apsarases and gandharvas, the Indo-Aryan equivalent of the water nymphs of the Indus Age.
- 6.35 Yama is considered to be the first-born among mortals. Yama and his twin sister Yamī were the progenitors of the human race. In their famous dialogue (*RV* 10.10), Yama appears to resist the sexual advances by Yamī. This is a telling detail indicating the pre-Aryan origin of the legend with which the Aryan society felt uncomfortable. Yama was the first mortal to die and went on to become the king of the world of the departed. In later literature, Yama became the terrifying God of Death. To sum up, the following alternative interpretations seem to be possible (Fig.6.14).



Sign Sequence	Pictorial identification	Dravidian interpretation	Indo-Aryan equivalents
	twin FISH- he	<i>iṇ-ay/ir-aṇ (min)-anr(u)</i>	<i>yama</i>
	twin FISH- She	<i>iṇ-ay/ir-aṇ (min)-amp(u)</i>	<i>yamī</i>
twin water nymphs of Heaven and Earth (<i>rōdasī</i>);			

Fig.6.14 Interpretation of TWO TALL LINES + FISH Sign (in Fig.6.4 G) .

The Seven Water Nymphs : Source of the ‘Seven Mothers’ Cult

- 6.36 Among the innumerable mother-goddesses of the Pre-Aryan tribes and villages absorbed and assimilated into the Sanskritised Hindu pantheon, the group of Seven Mothers (*sapta-mātrī*) stands out. It is significant that the Seven Mothers are referred to in Tamil tradition as the *catta kanniyar* ‘Seven Virgins’ (*Piṅkala.*) They are virgin-mother-goddesses. Sculptures of the *catta kanniyar* (also called *sapta-mātrī*) are ubiquitous in Tamilnadu from early medieval times (Fig.6.15). The names by which the individual goddesses are known, like *Brāhmī* etc., are derived from later Sanskrit sources (*Piṅkala. & Cūṭamaṇi*). In the Māvaḷ region of Maharashtra, the mother goddesses are identified with the seven apsarases (*sātib āsārā*) who are always located near water bodies and referred to in the plural (Kosambi 1962: p.61). They provide a crucial link between the Northern Seven Mother Goddesses and the Southern Seven Virgins.



Fig.6.15 The Seven Mothers (*sapta-mātrī*) panel. Kailasanatha Temple, Kanchipuram. 8th cent. CE.



Fig.6.16 The Seven water nymphs present at a sacrifice. (Mohenjodaro, seal : Mackay No.430) .

I propose that the Seven Water Nymphs of the Indus Civilisation are the ultimate source of the Seven Virgin-goddesses (*catta kanniyar*) of the Tamil tradition and the Seven Mothers(*sapta-mātrī*) of the Sanskrit tradition. The Seven Water Nymphs may be seen standing in a row in the famous seal from Mohenjodaro depicting a human sacrifice (Mackay : No.430. See Fig. 6.16). They are seen wearing knee-length skirts, single-plumed headdress and sport long, plaited pigtailed. They wear bangles on both arms from shoulder to wrist (cf. Figs. 6.10 A&B). They are probably the chief priestesses heading each of the seven groups

of water nymphs (Fig.6.4. A to G). Near-replicas of the scene with seven water nymphs have also been discovered on a seal from Harappa (Vats : No.251) and on terracotta sealings from Mohenjodaro (e.g., *CISI- I* : M.442).

Evolution of ARROW sign as symbol of ‘goddess’

- 6.37 An important clue for the proposed identification is the FISH-ARROW pair of signs which represents the female water nymphs (Fig. 1.15). The ARROW is *ampu* in Dravidian (DEDR 178). The sign signifies, through rebus, *-(a)mp(u)*, the non-masculine (feminine in the present context) singular suffix (Fig.1.14). The suffix evolved into *-am(m)-* forms in Dravidian languages as shown below:

Old Telugu : *-(a)mbu* > *-(a)bu*, *-(a)mmu*, *-(a)mu*

Old Kannada : *-(a)m*, *-(a)mu* > *-(a)vu*

Tamil : *-(a)m*

It is useful to remember here that when one proceeds to compare Indus-Dravidian feminine nouns with the corresponding Old Tamil forms, the earlier non-masculine suffix *-(a)mp(u)* has to be replaced with the feminine gender suffixes in Old Tamil, namely, *-ay*, *-i*, or *-aḷ* / *-āḷ* / *ōḷ*.

Thus, Indus-Dravidian *mū-(a)mp(u)* > Old Tamil *mū(-tt)-āḷ*, *mū(-tt)-ōḷ* etc.

It is now accepted that IA *amba* ‘mother’ already occurring in the *RV* is a loanword from Dravidian *amma* ‘mother, goddess’ (so in DEDR 183). Thus, the *-(a)mpu* / *-(a)mma* ending of female names in Dravidian was in later times identified with *-amba* in Indo-Aryan. In the *AV*, the apsarases are called *māṭṛi-nāmāni*, having the name ‘mother’, i.e. ‘mother-goddesses’. Kosambi (1962: p.71) points out that all goddesses whose names end in *-mā* in Sanskrit (as in *umā* etc.) are ‘mother goddesses’. In South India, all village goddesses have *-ammā* as the universal suffix to their individual names.

- 6.38 In a parallel development, the ARROW sign appears to have evolved into a religious symbol in later times and identified as the ‘lance’ which is closely associated with the mother goddess (Skt. *śakti* > Ta. *catti*). The association is so close that the weapon itself came to be called *catti* (*Tamil Lexicon*). This development is analogous to the evolution of the Indus sign  ‘great’ into the religious symbol ‘trident’ (*śūla*) associated with Śiva (Mahadevan 2008). The suggestions relating to the evolution of the significance of the ARROW sign in later times are summarised in Fig.6.17.

Sign	Pictorial Identification	Dravidian Equivalents			Indo-Aryan loanword
		literal	by rebus	Later	
↑	Arrow (later, 'lance')	<i>ampu</i> 'arrow'	<i>-(a)mp(u)</i> '-she' (fem. Sg. suffix)	<i>amma</i> 'mother, goddess'	<i>amba</i> 'mother, goddess'

Fig.6.17 Evolution of ARROW sign ('-she') to signify 'mother, goddess'.

The Senior Priestess ↑||| : Evolution of *Mū-dēvi* / *Jyēshthā*

6.39 ↑|||↓ is the most frequent three-sign sequence in the seal-texts attesting to its importance to the seal-owning ruling classes (see Para 6.48 below). While we shall consider the significance of this sequence more fully in part II of this study, it is convenient to discuss the sign-pair ↑||| in the present context along with the interpretation of the ARROW sign discussed above.

||| : The 'three tall lines' sign indicates some idea connected with the numeral 'three', most probably through the rebus method :

Literal : cf. *mu-*, *mū-*, *mūnr(u)* 'three, third, triple' (DEDR 5052).

Intended : cf. *mū-*, *mut(u)*, *mū(tt)-*, *mū(pp)-* 'old, ancient, elder, senior, great, superior, head, leader' (DEDR 4954).

cf. Ta. *mutiyāl* 'woman possessed by spirit' (*Maṇi*. 18:144) ; *mutiyōl* 'elder sister' (*Piṅkala.*) ; *mūppi* 'woman of distinction' (DEDR 4954).

Hence ↑||| : *mū-(a)mp(u)* 'senior-she' i.e. 'Senior Priestess'.

6.40 All the four literary Dravidian languages have, in addition, the hybrid name *mū-dēvi* (in Ma., Ka., and Te.) or *mū-tēvi* (in Ta.) with the meaning 'elder sister



(of Lakshmi), goddess of ill-luck or misfortune' (DEDR 4954). The Tamil words for 'elder sister, goddess' cited above are also used as synonyms for *mū-tēvi*. The name of the goddess is rendered in Sanskrit as *jyēshthā (dēvī)*. Her stone sculptures dating from the early medieval period still dot the Tamil countryside (Fig.6.18).

Fig.6.18 Jyēshthā(*mū-dēvi*)

Perangiyur, Tamilnadu. 10th cent. CE.

- 6.41 The historical development is fairly obvious. When Lakshmī as *Srī-dēvī*, the ‘goddess of good fortune’ came into prominence in South India after the spread of Sanskritic culture, the earlier, indigenous goddess was relegated to the background as a village deity. Though she still managed for some time to retain her position as the ‘Elder or Senior Goddess’ (Ta.*munṇava*], *munṇai*, *mutiyō*], *mūttō*]), her hybrid and Sanskrit names *mū-dēvi* and *jyēshṭhā*, acquired a pejorative sense in course of time to mean ‘goddess of ill-luck or misfortune’. She is no longer worshipped even as a village deity.

Indus origin of the *Tryambaka* legend ↑ |||

- 6.42 An exceedingly interesting confirmation of the proposed interpretation ↑ ||| :*mū-(a)mp(u)* ‘THREE-ARROW’ (literal) > ‘Senior (Priestess) -she’ (intended), is provided by the title *tryambaka* ‘one with three mothers’ accorded to Rudra in the *RV*. The expression occurs in the famous *mṛityu-mōcanī* mantra (*RV* 7.59.12) repeated in the *Yajurveda* :

tryambakam yajāmahē sugandhim puṣṭivardhanam

‘we worship Tryambaka, the Fragrant one, who increases prosperity’.

The same conception is implied in another expression occurring in the *RV* (3.56.5), *trimātā* ‘one with three mothers’.

- 6.43 I suggest that these expressions are hybrid loanwords-cum-translations from the earlier Indus-Dravidian THREE-ARROW : *mū-ampu* as shown below:

↑ ||| :*try-* Skt. ‘three’ (from Dr.*mū-* ‘three’ and ‘senior’)
-amba- Skt. ‘mother’ (from Dr.*ampu* ‘arrow’ and *amma* ‘mother’)
-ka Skt. masc. suffix indicating ‘one with (three mothers)’.

The ‘three mothers’ of Rudra have been identified with *ambā*, *ambikā* and *ambālikā*. These names are also derived from Dr.*amma-* >IA *amba* ‘mother, goddess’ (DEDR 183). *Ambikā*, a post-Vedic name of Śiva’s wife, is mentioned for the first time in *VS* appearing here not as Rudra’s wife, but as his sister (*Vedic Mythology*: p.74).

- 6.44 Still later (in the *Mbh.*), *Ambā*, *Ambikā* and *Ambālikā* appear as the three daughters of the king of Kāśī. They are abducted by Bhīshma to be married off to his step-brother, Vicitravīrya; but *Ambā*, the eldest, kills herself after taking

the vow that she would be re-born to kill Bhīshma. The two younger sisters married Vicitravīrya (*Mbh. Index*). Commenting on the episode, Kosambi points out that all the three names mean ‘mother’ (*amba*) and are also connected with the waters (*ambu*). (Kosambi 1962: p.61).

6.45 It is instructive to compare the four hybrid loanwords-cum-translations originating from the Indus - Dravidian $mū-(a)mp(u) \uparrow |||$:

(i) *try-amba(-ka)*; (ii) *tri-māṭṛi*; (iii) *jyēshṭhā (dēvī)*; (iv) *mū-dēvī*.

The expressions are good examples of bilingual parallels evolved from the close interaction between Dravidian and Indo-Aryan in the post-Indus Age. The first two, occurring in the *RV*, have not retained the original meaning; the next two, attested from later times, are much closer to the original due to the increased influence of the Dravidian element.

Indus origin of the *Tripura* legend $\uparrow |||$

6.46 The legend of *tripura* ‘Three Cities’ is as old as the Brāhmaṇas (*ŚBr.* and *AiBr.*). The myth as told in the *Mbh.* is briefly as follows : The Asuras lived in three aerial cities made of gold, silver and iron built by Maya. The cities roamed at will in the skies and posed a grave threat to people on the earth. Indra could not vanquish them. The gods asked Rudra for help. Rudra shot and burnt down the three cities with a single arrow, and was hence known as *Tripura-ghna* ‘destroyer of Three Cities’ (*Mbh. Index*).

The legend also occurs in Old Tamil as early as in the Caṅkam anthologies.

cf. *oru kaṇai koṇṭu mū-cyil uṭarri*

‘(when Śiva) fought the Three Cities with a single arrow’ (*Pura.55:2*).

In later Tamil Śaiva tradition, the theme of *Tripurāntaka* became very popular.

6.47 I suggest that the legend of *Tripura* is of Indus-Dravidian origin and was borrowed into Indo-Aryan in the following manner :

$\uparrow |||$: *mū-ampu*. ‘THREE ARROW’ (in the literal sense).

(a) *mū* was interpreted literally as ‘three’ (DEDR 5052).

(b) *ampu* ‘arrow’ (DEDR 178) was replaced within Dravidian by-

(i) *ayil* ‘lance, javelin’ (DEDR 193) from the pictorial resemblance of the lance to an arrow (cf. Fig.6.17);

(ii) *ayil* ‘metal, any ore, iron’ (DEDR 192), homophone of *ayil* in (i);

(iii) *eyil* ‘fortress, wall, city’ (DEDR 808), near-homophone of *ayil*.

(c) *tri-pura* (Skt.) literal loan translation from Dr.*mū-eyil* ‘three cities’.

Note how several small details of the myth confirm its Dravidian origin. The near-homonymy between Dr.*ayil* / *eyil* is the basic element of the myth. The idea that the cities were made of ‘metal’ is based on the homonymy between *ayil* ‘lance’ and *ayil* ‘metal’. The Three Cities were ‘flying’ like arrows and were shot down by a ‘single arrow’, elements based on the ARROW ideogram of the sign-pair. The cities were ‘burnt’ because *eri* ‘to discharge (as arrow or lance)’ (DEDR 859) was confused with *eri* ‘to burn’ (DEDR 811). The reference to ‘iron’ may indicate that the myth took final shape only in the Iron Age; alternatively, ‘copper’ in the earlier (unrecorded) version might have been replaced by ‘iron’ later. The word *ayil* ‘metal, any ore’ (DEDR 192) is a general term which could have included copper / bronze as well.

Senior Priestess of the (Sacred) Pool

6.48 : The MORTAR & PESTLE sign is interpreted, through rebus, as follows :

kur- /*kuṭ-* ‘to pound’ and *kuḷ-* ‘to grind’ > *kuṇṭ(a)* ‘pool’ > IA *kuṇḍa* ‘water body, (later) fire-pit’. Thus, the sign stands for the ‘Sacred Pool’ (Mahadevan 1970, with updated version in Part II of this paper). The sign has also ideographic values derived from the verbs ‘to pound, grind’ (Mahadevan 1983). Textual evidence indicates that, during the Indus Age, the title:

 : *kuṇṭ(a)-mū-amp(u)* ‘Senior Priestess of the (Sacred) Pool’

referred to the water nymphs and not to the ‘elder mother goddess’ (*mū-dēvī*) as she evolved in later Indian tradition . In fact, it appears from the texts that in each of the seven classes or groups of water nymphs (Fig.6.4A to G), there were ‘Senior Priests and Priestesses of the (Sacred) Pool’, a title held by the senior most among them (by age or rank).

Gandharva : Dravidian origin identified

6.49 Information on the gandharva, the male consort of the apsaras, is scanty in the *RV* (See Para.4.2). However, in later Sanskrit literature, the gandharvas are many in number and are grouped together into large *gaṇas* (‘troops’) along with the apsaras (*Mbh. Index*). The later tradition does not appear to be an innovation, but represents the re-emergence of the Pre-Aryan legends relating to the water

nymphs and their male companions . The ‘merman-mermaid’ pair depicted on the Babylonian button seal (Fig.2.2) indicates the probable existence of a similar institution in the closely analogous Indus religion centred around the Sacred Pool.

- 6.50 The origin of the gandharvas can be traced to the Indus Civilisation where they figure as the male consorts of water nymphs. In the Indus texts, every FISH-ARROW pair (representing the female nymph) is matched by the corresponding FISH-JAR pair (representing the male nymph) (Fig. 1.15). The male nymphs occur with much less frequency than the female nymphs in the Indus texts indicating the subordinate role of the former (Paras. 1.18&1.19). This inference is quite in accord with the known relationship between the apsaras and the gandharvas in Sanskrit literature (Paras 4.1 & 4.2), and the supporting role of the male companions of the Dancing Girls in the medieval South Indian temples (Paras 5.6 to 5.9).
- 6.51 It is surprising that there is no mention in the Caṅkam literature about the male consorts of the *ara-makalir* ‘divine damsels’ (Para.5.1). No Dravidian or Old Tamil term for the *gandharva* has so far been identified. The medieval Tamil commentaries and Nikaṅṅus employ the term *kantaruvar* borrowed from Skt.*gandharva*. The medieval Tamil temple inscriptions also refer to the *kantaruvar* among the male supporting staff of the Dancing Girls attached to the temples. However, it appears unlikely that the gandharvas who figure prominently in Sanskrit literature and whose origin has been traced in the present study to the Indus Age, were unknown to Dravidian and Old Tamil traditions. This led to a search in early Sanskrit literature for possible clues to help locate the elusive gandharva in earlier Dravidian times. And the clues did turn up.
- 6.52 The first clue is the role of the gandharva as the ‘husband’ *par excellence*. The gandharva is sometimes described as the ‘husband’ of the apsaras, though he was by no means her lord and master. The union of gandharva with apsaras is considered to be typical of marriage. The gandharva is connected with the wedding ceremony. The unmarried maiden is said to belong to the gandharva. Viśvāvasu, the gandharva, is regarded as the rival of the husband in the first days of wedlock (*Vedic Mythology* : pp.136-137).

6.53 The second clue is from etymology. The expression *gandharva* is said to be derived from *gandha* ‘fragrance, smell, odour’ though the two conceptions “appear to have nothing in common” (*Vedic Mythology* : pp.136-137). The methodology of bilingual parallels pursued in the study of the Indus script indicates that if *gandha* cannot be connected with *gandharva* in meaning, the problem is probably due to homophones related in sound but unrelated in meaning in the original Dravidian :

cf. Ta. *maṇa* ‘wed, live in company with’; *maṇam* ‘marriage’; *maṇavāḷaṇ* ‘bridegroom, husband’; Ma. *maṇam* ‘marriage’; *maṇāḷaṇ* ‘bridegroom, husband’; Te. *manumu*, ‘marrying a husband’; Go. *marmin* ‘marriage’. Malt. *manye* ‘to love, marry’ (DEDR 4667).

Compare the above with the meanings of the following homophone :

cf. Ta. *maṇa* ‘to emit fragrance’; *maṇappu* ‘scent, odour’; *maṇam* ‘fragrance’; Ma. *maṇakka* ‘to yield a smell, smell’; *maṇam* ‘smell’ (DEDR 4668).

The linguistic evidence indicates that Dr.*maṇ(a)*- ‘wed, marriage, husband’ is the source of the IA loan translation *gandharva*, while the homophone *maṇ(a)*- ‘fragrance, smell’ is equivalent to IA *gandha* with the same meaning. The fact that the homophones occur only in Dravidian proves that Dr. *maṇ(a)*- is earlier than, and is the source of, IA *gandharva* (*RV*). There is an interesting corroboration in the *RV* itself to the proposed derivation. The only *gandharva* mentioned in the *RV* is Viśvāvasu whose name is said to mean ‘possessing all goods’ (*Vedic Mythology*: p. 136). Compare this etymology with the following :

cf. Ta. *maṇam* ‘prosperity, affluence’; *maṇappu* ‘possession of extensive properties’ (DEDR 4667).

Note that *Viśvāvasu* (*RV*) and Ta. *maṇappu* have identical meanings. The context suggests Dravidian to be the earlier source.

6.54 What about the ‘missing’ *gandharva* in Old Tamil? The evidence adduced above indicates that the conception of *gandharva* as the ‘ideal husband’ merged into the more general meaning of *maṇavāḷaṇ* ‘bridegroom, husband’ and lost its specialised meaning of the ‘male consort’ of water nymphs (*ara-makalīr*). In the Vaishnava tradition, Vishṇu is the *maṇavāḷaṇ* ‘the eternal bridegroom’ .

cf. *maṇāḷa nampī* ‘Oh bridegroom -lord (Vishṇu)’ (*Nālāyira. Periyālvār*:5.4.9); *maṇavāḷīr* ‘Oh bridegroom - lord (Vishṇu)’ (*Nālāyira. Tirumaṅkai*:10.8.7).

The Viṣṇu temple at Srirangam has a shrine for Aḷakiya-Manāvāḷan ‘handsome bridegroom’. This religious tradition may also have contributed to the eclipse of the earlier association of *maṇa-* with *gandharva*. The linguistic evidence makes it probable that the generic name of the male consort of the apsaras in the Indus-Dravidian was *maṇa-*. Individually, the male nymphs share the same titles as the corresponding female nymphs, but with the gender suffix altered accordingly. FISH-ARROW pairs represent the proto-apsarases and FISH-JAR pairs the proto-gandharvas of the Indus Age (Fig. 1.15).

The PARTRIDGE and the FISH motif

- 6.55 One of the BIRD signs in the Indus Script, which can be identified, depicts the partridge, a smallish, rather plump bird with a small beak, striped body and a short down-turned tail (Fig 6.19). The PARTRIDGE sign (turned vertical to save space on seals) also occurs within an ‘enclosure’, sometimes coupled with the FISH sign in either order (Fig.6.20 : 1-4).



Fig.6.19 PARTRIDGE
(K. Ratnam 2002 :No.59)

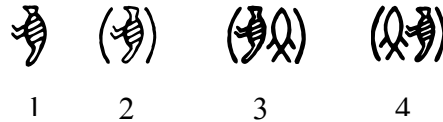

Fig.6.20 PARTRIDGE signs in the Indus Script
(ASI Concordance 1977)

The partridge was known as the *pūḷ*, and the related smaller bird, the common quail, as the *kuṛum-pūḷ* (lit., the ‘smaller partridge’) in the Caṅkam anthologies. In later Tamil, these names have been replaced by *kautāri* (partridge) and *kāṭai* (quail). Apart from accurate physical description of the birds, the Caṅkam poems also refer to the custom of rearing and training them to fight.

cf. *pūḷ-iṅ pōrval cēval* ‘ the combative male partridge’ (*Pura*. 321 : 1).

(For details and references, See P.L. Samy 1976 : pp.205-214.)

cf. Ta.*pūḷ-āṅ* ‘Indian partridge’, *kuṛum-pūḷ* ‘quail’;

Te. *pūrēḍu* ‘bird resembling the quail’ [partridge?];

puridi-piṭṭa ‘quail’ (DEDR 4374. The identification of *pūḷ* as ‘quail’ in DEDR is based on late Tamil sources ; see P.L. Samy 1976 on this. Note Ta.-/ > Te. -r.)

The Pūliyar clan in the Caṅkam Age

- 6.56 The Pūliyar were a war-like people serving in the Cēra army during the Caṅkam Age. Their name is always mentioned in the plural in the Caṅkam poems. The Cēra kings prided themselves on being the patrons of the Pūliyar. Their association was so close that the Cērar were themselves known as the Pūliyar (*Tivā. & Piṅkala.*).

cf. *pūliyar kō* ‘king (Cēra) of the Pūliyar’ (*Patir.*21.12 & 84.6);

pūliyar mey-m-maṛai ‘(Cēra for whom) the Pūliyar (formed) the bodyguard’ (*Patir.*73.13 & 90.27).

(For further details and references on the Pūliyar, See Durai Rangaswamy 1960: pp.256-258).

The land of the Pūliyar was known as *Pūli-nātu*, identified with Koṅkāṇam (South Konkan). It is significant that, according to Old Tamil sources, the Vēḷir and Kōcar clans also hailed from this region which seems to have been the route taken by the migrating tribes from the Indus to the Tamil country (For details, see Mahadevan 1970 & 2009a). The Pūliyar may be regarded as descended from the *pūḷ* ‘partridge’ clan of the Indus Age represented by the PARTRIDGE sign in the Indus Script. It is likely that the Pūliyar chose the *pūḷ* ‘partridge’ as their totem or clan symbol because of the proverbial fighting spirit of the bird.

The Pūru People in the *RV* and later

- 6.57 *Pūru* occurs as the name of a people in the *RV* (1.108.8). *Paura*, a ‘descendant of Pūru’ is also mentioned in the *RV* (8.3.12). The disappearance of the Pūru people from the later Vedic tradition is attributed to their merger with the Kuru clan. The royal families of the Pūru and the Kuru were linked by inter-marriage (*Vedic Index*). The Pūru tradition was revived in the Epic period. The *Mbh.* mentions Pūru as the son of Yayāti. One of the descendants of the Puru / Pūru clan, a Paurava prince, is identified in Greek sources as Poros who fought with Alexander in the Panjab. Though defeated, Poros was able to stem the advance of Alexander further into India (Kosambi 1965: pp.134-138).

I suggest that *Puru / Pūru* (> *Paura, Paurava, Pauru*), a people mentioned the *RV* and the *Mbh.*, and who survived as a powerful warrior tribe well into the Mauryan Age, were descended from *Pūḷ* ‘the partridge clan’ of the Indus Age,

like their remote Dravidian kinsmen, the Pūliyar, also a warrior clan, of the Caṅkam Age in the Tamil country. The IA name of the clan is most probably a loanword from a Dr. dialect in which *pūl* > *pūr*- (as in Telugu). Another example, also from the Panjab, is the name of the Dravidian tribe *Maḷava*- which was borrowed into IA as *maḷava*>*mālava*. The name can still be recognised in *Mālwa*, a region in the Panjab.

Purūravas was the founder of the Aiḷa (<Iḷā) line. The great Pūru kings, Purukutsa and Trasadasyu are mentioned in the *RV*. The *Mbh.* traces the famous Lunar Dynasty from Purūravas, whose illustrious descendants include Puru, Dushyanta, Kuru and Bharata as well as the Kaurava and the Pāṇḍava princes, the central figures in the Epic (*Mbh. Index*).

Purūravas and Urvaśī

- 6.58 Purūravas is the hero in a hymn of the *RV* (10.95) containing a dialogue between him and Urvaśī, the apsaras. The account in the *RV* appears to be incomplete ; but more details of the story are found in the *ŚBr*. The story in brief is as follows : Purūravas, the son of Iḷā, falls in love with Urvaśī. She consents to be with him but on the condition that she should not be seen naked by him. The jealous gandharvas produce a flash of lightning when the couple are together, and Purūravas sees Urvaśī naked. She disappears instantly. Purūravas goes in search of her and, after a long time, finds her in the form of an aquatic bird swimming in a lake with other apsaras. The couple are eventually reunited, and Purūravas himself becomes a gandharva. The story is also the theme of the famous play *Vikramōrvaśīyam* by Kalidasa.

Purūravas and Urvaśī : A new interpretation



- 6.59 The name *Purū-ravas*, a compound of *puru* + *ravas* , is said to mean ‘calling aloud’ (*Vedic Mythology* : p.135). However, I suggest that this name is a hybrid expression made up of Dr.*pūr(u)*-(<*pūl*) ‘partridge’ and IA *-ravas* ‘call’. The new interpretation points directly to the legend of Purūravas in the *RV*. There is a pun here, the well-known call (*-ravas*) of the partridge(*pūr*-) being compared to Pūru calling (Urvaśī).



Fig.6.21 PARTRIDGE & FISH (in) ENCLOSURE.

Terrocotta sealing. Mohenjodaro.

Mackay Pl.XCVI :10. Recalling the Dialogue of Purūravas and Urvaśī (*RV* 10.95).

I draw attention to a cylindrical terracotta sealing found at Mohenjodaro, featuring a pictorial motif, a partridge and a fish side by side within an enclosure (Fig.6.21). Several duplicates of the sealing have been found indicating the popularity of the motif imprinted on it. As the partridge and the fish are found in either order within the enclosure (see Fig.6.20), it would be more appropriate to regard this as an art motif rather than a text. In the light of the famous dialogue in the *RV*, we can interpret the motif on the Indus sealing thus :

‘He of the PARTRIDGE clan (*pūru-*) calling (*-ravas*) the FISH (apsaras)’.

I have earlier interpreted the signs within the enclosures as ‘functionaries or institutions within or associated with the Citadel’ (Mahadevan 2009b). In the present case, the FISH (water nymph) within the Enclosure can be compared with Old Tamil *āyattār* (< *aka-tt-ār*) ‘women of the inner chambers’; cf. Skt. *antaḥpura* in the same sense (MW). The fragmentary dialogue in the *RV* is probably based on a popular Indus-Dravidian play or ballad with PARTRIDGE (clan name) as the hero and FISH (water nymph) as the heroine. As I have explained earlier (Para 6.3), the plain FISH sign in the Indus script stands for the generic name of the water nymphs and can also stand for *Urvaśī*, the ‘great water nymph’.

Partridge and the *Taittirīyam* (*Yajurveda*)

- 6.60 The partridge is known as *tittira* or *tittiri* from the late Vedic period (*VS*, *TS*, *ŚBr.*). The name is an onomatopoeic formation from the characteristic call of the partridge sounding *tīt tīt*. *Tittiri* is also the name of a pupil of *Yāska*. *Tittiri* is reputed to be the first Teacher of the *Taittirīya* school of *Kṛishṇa* (‘Black’) *Yajurveda* (*YV*). The names *Tittiri* and *Taittirīya* appear to be connected with *tittiri* ‘partridge’. It is possible that the earlier Indus-Dravidian Partridge clan (*Pūl*, represented by the PARTRIDGE sign in the Indus script) split into two branches in the late Vedic period, a Kshatriya branch, the *Pūrus*, and a Brāhman branch, the *Taittirīyas*, their names being respectively a loanword and a loan translation from *Dr.pūl* ‘partridge’.
- 6.61 A legend narrated in the *Vāyu Purāṇa* confirms that the connection between *tittiri* ‘partridge’ and *Taittirīya* is not merely fortuitous. (The following summary is

taken from Monier Williams Dictionary.) The *YV* was first taught by Vaiśampāyana to 27 pupils including Yājñavalkya. Subsequently, Vaiśampāyana, being offended with Yājñavalkya, bade him to disgorge the Veda committed to him, which he did in a tangible form ; whereupon the older disciples of Vaiśampāyana being commanded to pick it up, took the form of partridges and swallowed the soiled texts, hence named ‘black’, the other name *taittirīya* referring to the partridges. Yājñavalkya then received from the Sun a new or ‘white’ version of the *YV*(MW).

Partisan and rather repulsive the legend may be, but it does contain a clue to the Dravidian origin of the Taittirīyas. There is an implicit pun in the story :

cf. *pūl*, *pūl-āṇ* ‘quail, partridge’ (DEDR 4374).

puḷu (*n.*) ‘worm, maggot’ ; *puḷu-pp-*, *puḷu-tt-(v.)* ‘to breed worms, to be worm-eaten, putrefied, putrid’ ; Te.*purugu* ‘worm’; *phullaka* (Skt.) ‘worm’; *phūl* (Hindi) ‘maggot hatched in meat’ (DEDR 4312).

According to the legend, the partridges (*pūl-*) swallowed the putrefied, worm-infested (*puḷu-*) vomit (‘black’ and ‘soiled’ texts). Puns are language-specific, and this pun can be made only in Dravidian. The legend thus confirms the Dravidian origin of the Taittirīyas.

It is noteworthy that only the Pūrus, the warrior clan of the North, had their counterpart in the Pūliyar, the Cēra warrior clan of the South. The Taittirīya Brāhmins, along with the followers of other branches of the Vedas reached South India much later. The Caṅkam anthologies (early centuries C.E.) mention *nāṇ-marai* ‘Four Vedas’ (*Aka.* 181:16; *Pura.* 362 :9) , but not the names of any specific branch.

- 6.62 There is an interesting (but problematic) link between the *Taittirīyam* and the Pūliyar (Cēra) mentioned by Tirumaṅkai Aḷvār (ca.8th century C.E.) in the same verse (*Periya Tirumoli* : 7.7.2 & 7.7.4). I shall cite the relevant lines with my translation and then discuss the problem posed by the traditional interpretation and suggest a solution based on the evidence summarised above.

cantōkā! paḷiyā ! taittiriyā! cāmavētiyaṇē! neṭumālē! (7.7.2) ;

paraṇē ! pañcavaṇ paḷiyaṇ cōlaṇ pār maṇṇar maṇṇar tām ēttum (7.7.4).

‘Oh Neṭumāl (Vishṇu) (of the) Chāndōgya (Brāhmaṇa of the Sāmavēda), **Pauliya** (Taittirīya? branch of the Yajurvēda), Taittirīya (branch of the Yajurvēda) (and) Sāmavēda’ (7.7.2) ;

‘Oh the Supreme One (Vishṇu) ! (you are) praised even by the Pañcavaṇ (Pāñṭiyaṇ) , **Pauliyaṇ** (Cēraṇ?) (and) Cōḷaṇ, the kings of kings of the world’ (7.7.4).

There is only one word **Pauliya(n)** for which I offer an interpretation which differs from the tradition. We shall look into the second line (7.7.4) first, as it is the easier one to interpret. There can hardly be any doubt that **Pauliyaṇ**, wedged in between the names *Pañcavaṇ* (Pāñṭiyaṇ) and *Cōḷaṇ* , must refer to Cēraṇ, the third of the *mūvēntar* of the Caṅkam polity. This reasonable interpretation has in fact been followed in the *Tamil Lexicon* which, however, interprets the same word *Pauliya(n)* in Tirumaṅkai 5.5.9 & 7.7.2 as ‘god as described in the Ṛigvēda (<*bahvṛic*)’. The suggested derivation of *pauliya(m)* (also spelt *pavīliyam*, *pavūliya(m)*, *pauṭikam*, *pauṭiyam* etc., in different Tamil works) from Skt. *bahvṛic* is linguistically untenable. This derivation seems to be based on the traditional but incorrect interpretation of *Pauliyam* as the ‘Ṛigvēda’ found in medieval Tamil works (Naccīṅārkkīṇiyar’s commentaries on *Tolkāppiyam* and *Kalittokai*, and the medieval lexicons *Tivākaram*, *Piṅkalantai* and *Cūṭamaṇi*). However, the present study leads to the conclusion that *Pauliya-* in Tirumaṅkai. 7.7.2 refers to the *Taittirīya* branch of the Yajurvēda, although repetitively, as in the case of the Sāmavēda; and *Pauliyaṇ* in Tirumaṅkai. 7.7.4 refers to the *Pūliyar*, another name of the Cēra kings. The connecting link between the two homonyms is the symbolism of the partridge supported by the *Vāyu Purāṇa* legend cited above, which links the Taittirīyas with the partridge. The initial *pau-* in the Tamil words cited above indicates borrowing and re-borrowing between Dravidian and Indo-Aryan as suggested below :

Dr.*pūl-* ‘partridge’, *pūli-* , *pūliyam* ;

> IA **pauṭiya-* / **pauṭika-* ;

> Ta. *pauṭikam*, *pauṭiyam*, *pauliyam*, *pavūliyam*, *pavīliyam* ‘ Taittirīya branch of the Yajurvēda’.

The Gharial and the Fish : A symbolic Motif

6.63 The gharial (*Gavialis Gangeticus*) is a large, fish-eating crocodile with a long, narrow snout widening at the nostrils. It is native to the Indian sub-continent. It is mostly found in the Ganga and the Yamuna, but in ever-decreasing numbers as the water in the rivers has become highly polluted. The gharial is known as the *makara* in Sanskrit > *magar* in Hindi > *mugger* in English. The name *makara* has been borrowed into Tamil from very early times, but only in the sense of a mythical animal with fabulous features. It is sometimes confused with the shark or the fish. The *makara* motif occurs in South Indian temple architecture (*makara-tōraṇam*) and in gold ornaments (*makara-kunḍalam*).

6.64 The gharial must have flourished in large numbers in the Indus river and its tributaries in the Indus Age. The crocodile depicted on the Indus seals, sealings and miniature tablets can be clearly identified as the gharial from its long, narrow snout. The symbolic significance of the gharial motif can be understood from :

- (a) the frequent association of the gharial with the fish (in Indus art) ;
- (b) Mythology of the *makara* centred on love (in literature) ;
- (c) The fabulous and composite features of the gharial (in Indus art) and the *makara* (in later architecture).

6.65 The gharial motif occurs only rarely on the Indus seals (Figs. 6.22: 1&2), but much more frequently on terracotta sealings and miniature tablets (tiny seals and sealings) with or without accompanying inscriptions. The following characteristic modes of depicting the gharial are relevant to our study:

- (i) Gharial holding a fish in its jaw, and / or surrounded by a school of fish (Figs. 6.22 : 2-4) ;
- (ii) Gharial as a composite, fabulous creature by combining with it parts of animals (which occur as the main field symbols on seals) (Fig. 6.22: 5) ;
- (iii) Gharial shown above a series of animals in file (Figs. 6.22:6A&B);
- (iv) A row of three gharials in file surrounded by schools of fish (Fig. 6.22:7).



1. Seal. Mohenjodaro.
(Marshall : 361)



2. Seal. Mohenjodaro.
(Mackay : 133)



3. Sealing. Mohenjodaro.
(*C.I.S.I.* v.2 :M-1429)



4. Sealing. Harappa.
(*C.I.S.I.* v.1 : H-172)



5. Sealing. Mohenjodaro.
(*C.I.S.I.* v.1 : M-440)



6. Sealing. Mohenjodaro.
(Marshall: CXVIII-10 A&B)



7. Sealing. Chanhudaro.
(Mackay : LII-33)

Fig.6.22 Gharial in the Indus Glyptic Art

- 6.66 The most prominent aspect of the *makara* in literature is its association with love. The *makara* is the emblem of Kāmadēva, ‘ the god of love’, who is hence known as *makara-dhvaja* in Sanskrit and *makara-k-koṭiyōṇ* in Tamil. Why is the *makara* associated with love? It is not a beautiful creature, whether one looks at the original gharial or the ‘sea-monster’ of mythology. The association would be incongruous but for the neat explanation offered by the Indus ‘gharial and fish’ motif : The gharial is a fish-eating crocodile; the FISH signs in the Indus Script represent water nymphs (the ‘Dancing Girls attached to the Sacred Pool’). If the nymph is symbolised as the ‘fish’, what is more natural than symbolising the priest consorting with her as the fish-eating ‘gharial’? To quote Kosambi again, “it was part of the ritual for men not only to bathe in the sacred water, but also cohabit with the female attendant representatives of the mother goddess”. (See Para 2.5 for details of the ‘Kosambi Conjecture’ and Section III for close West Asian parallels.) Thus the symbolic meaning of the motif of the gharial and the fish in the Indus art is ‘the priest cohabiting with the water nymph in ritualistic sex’. This is the origin of the myth of *makara* as the symbol of love in Indian literature.
- 6.67 The gharial does not represent the male nymph of the Indus Civilisation, corresponding to the *gandharva*, the male consort of the *apsaras* in Indo-Aryan tradition. The male and the female Indus nymphs are both depicted by identical FISH signs and can be differentiated only by the gender-marking suffixes attached to them (see Fig.1.15). Hence the gharial must represent some other person with the right of cohabitation with the female nymphs. In the present context, that person has to be the senior priest with access to the ‘Sacred Pool’ and the ‘love chambers’ built around it.
- 6.68 The *makara* is also visualised in mythology as a ‘monster’. The composite creature as featured in South Indian temple iconography is described by Ganapati Sthapati, the eminent sculptor from Tamilnadu, as “ a mythical animal with the body of a fish, trunk of an elephant, feet of a lion, eyes of a monkey, ears of a pig, and the tail of a peacock” (quoted by Janaki Lenin in her article on the *makara*. *The Hindu*, Chennai, January 15, 2011). (Fig.6.23).



Fig.6.23 *Makara* in temple iconography (Janaki Lenin 2011).

6.69 The conception of *makara* as a composite mythical animal appears to originate in the Indus motif of the gharial as a composite, fabulous animal. I shall refer in particular to two sealings from Mohenjodaro described below:

(a) **A rectangular terracotta sealing** (Fig.6.22:5; See especially the enlarged colour photograph of M.440 in *C.I.S.I.* vol.1:p.387:No.22, with clear details.):

A large gharial in vertical posture at the centre flanked on either side by animals:

left: a short-horned bull, a rhinoceros and an elephant, one below the other;

right: a short-horned bull and a long-tailed antelope, one below the other.

The animals are so arranged that the horns of the bulls are made to appear as the 'horns' of the gharial; the trunk of the elephant and the tail of the antelope together form the 'tail' of the gharial. Thus the gharial is turned into a fabulous, composite animal. Allowing for later elaboration in mythology, the parallel between the composite gharial of the Indus motif and the composite *makara* motif in mythology is too close to be mere coincidence,

(b) **A three-sided oblong terracotta sealing** (Fig.6.22:6A&B, illustrating sides 1&2 only; See especially the enlarged colour photograph of M.489 in *C.I.S.I.* vol.3.l:p.400, Nos.84 to86, for clear details.):

Side 1: in the upper register: a gharial with fish in its jaw;

in the lower register: four animals in file:

from the left: elephant, rhinoceros, an uncertain animal and tiger;

Side 2: in the upper register: a gharial;

in the lower register: four more animals in file:

from the left: unicorn, antelope, short-horned bull and buffalo.

Two significant features of the sealings described above are:

- (i) The gharial is depicted on a much larger scale relative to the accompanying animals, and placed at the centre or on the top;
- (ii) The animals depicted on the sealings are among those featured as the central pictorial motifs ('field symbols') on the seals.

6.70 The motifs on the sealings can be interpreted as showing the supremacy of the personage symbolised by the gharial over the clans or tribes symbolised by the animals which appear to be their totemic emblems. This inference is corroborated by many other pictorial motifs on the Indus sealings, some of which are summarised below:

- (1) The famous Paśupati ('Lord of Beasts') seal (Mohenjodaro : Mackay, No.420) depicts a seated buffalo-horned male personage surrounded by animals, all of which occur on the sealings in association with the gharial.
- (2) A unique three-sided terracotta sealing from Mohenjodaro (now in the Ashmolean Museum, U.K.) depicts on one of its sides the seated personage in the centre flanked on either side by a fish, a gharial and a serpent. (See especially the enlarged colour photograph of M-2033 in *C.I.S.I.*, vol.3.1: p.404, Nos.100-102 for clear details).
- (3) A two-sided terracotta sealing from Harappa depicts on one of its sides, the seated personage looking at a man hunting a buffalo; a gharial in the upper register. (See especially the enlarged colour photograph of H-1971B in *C.I.S.I.*, vol.3.1 : p.396, No.70 for clear details).
- (4) A terracotta sealing from Chanhudaro (Fig.6.22:7; Mackay 1935:Pl.LII-33) shows a procession of three gharials surrounded by schools of fish.

Gharial and the Fish motif : Summary

6.71 The combined evidence from the sealings leads to the following broad interpretations :

- (i) The gharial is a symbolic representation of the horned, seated male personage frequently depicted in the Indus art.
- (ii) Taking the overall archaeological and textual context into account, the horned seated male personage may be identified as a priest-ruler.
- (iii) The close association of the gharial with the main animals depicted on the seals indicate priestly authority over the clans represented by the totemic animals.
- (iv) The close association of the gharial with the fish indicates the special rights exercised by the priest-ruler over the water nymphs (dancing girls) attached to the Sacred Pool.

- (v) The Chanhudaro sealing shows that there were more than one priest-ruler, probably of equal status, controlling different clans represented by the totemic animals.

Conclusion

- 6.72 I have presented above an alternative Dravidian model for the interpretation of the FISH signs of the Indus Script. The most significant conclusion emerging out of the model is the extra-ordinarily close parallel not only linguistically with the Dravidian (which is expected), but also culturally with the Indo-Aryan from the earliest period of the *RV* (which is unexpected). The conclusion seems to be inescapable that, in the words of Kosambi (1962 :p.77), “The *Ṛigveda* shows the absorption of a pre-Aryan stream of culture, which goes into the very source and origin of Brahmanism”.

References

(Only modern works cited in the paper are listed here.)

- ASI Concordance* 1977. See Mahadevan, Iravatham 1977.
- Balasubramanian, Kudavayil 1987. *Cōla maṅṭalattu varalāṅṅru nāyakarkaḷiṅ cīrpaṅkaḷum ōviyaṅkaḷum*. Tamil University, Thanjavur.
- Burrow, T. 1968. *Collected Papers on Dravidian Languages*. Annamalai University.
- Champakalakshmi, R. 1981. *Vaishnava Iconography in the Tamil Country*. Orient Longman, New Delhi.
- A Dravidian Etymological Dictionary* 1984. Second Edition. (ed.) T.Burrow and M.B. Emeneau. Oxford. (abbr. DEDR with Entry Numbers; abbr. of names of Dravidian languages as in this source.)
- Durai Rangaswamy 1960 (1980). *Caṅka kāla-c- cīrappu-p-peyarkaḷ*. Chennai.
- Fairservis, Walter A. 1992. *The Harappan Civilization and its writing*. Oxford & IBH, New Delhi.
- Heras, H. 1953. *Studies in Proto-Indo-Mediterranean culture*. Bombay.
- Hunter, G.R. 1934 (2003). *The Script of Harappa and Mohenjodaro and its connection with other Scripts*. New Delhi.
- Janaki Lenin 2011. The Beast within [on *makara*]. *The Hindu*, Chennai. January 15th.
- Joshi, Jagat Pati and Asko Parpola 1987. *Corpus of Indus Seals and Inscriptions*. Vol. 1. Helsinki. (abbr. *CISI-I*).
- Kalaikkovan, R. 2004. *Talaikkōl*. Chennai.
- Kinnier Wilson, J. 1986. The case for accountancy in the Indus Script with a re-statement on the meaning and theory of “Indo-Sumerian”. *Tamil Civilization* 4(3&4) :pp.204-213.
- Knorozov, Yu.V. et al 1968. *Proto-Indica 1968*. Moscow.
- 1979. *Proto-Indica 1979*. Moscow.
- Kosambi, D.D. 1951. Urvaṣī and Purūravas. *Journal of the Bombay Branch of the Royal Asiatic Society (JBBRAS)*: pp.1-30.
- 1956(2008). *An Introduction to the Study of Indian History*. Bombay.
- 1962(2008). *Myth and Reality*. Bombay.
- 1965(2009). *The Culture and Civilisation of Ancient India in Historical Outline*. Bombay.
- Krishnamurthy, R. 1997. *Sangam Age Tamil Coins*. Madras.
- Krishnamurti, Bh. 2003. *The Dravidian Languages*. Cambridge University Press.

- Lal, B.B. 1979. *On the most frequently used sign in the Indus Script*. 10th ICAES, New Delhi. Indian Institute of Advanced Studies, Simla.
- Lockwood, Michael 2001. *Pallava Art*. Tambaram Research Associates, Chennai.
- Macdonell, A.A. 1898 (2002). *Vedic Mythology*. Delhi.
- Macdonell, A.A. and A.B. Keith 1912 (1995). *Vedic Index of Names and Subjects*. 2 vols. Delhi. (cited *Vedic Index*.)
- Mackay, E.J.H. 1937-38. *Further Excavations at Mohenjodaro*. 2 vols. Delhi.
- 1943. *Chanhudaro Excavations 1935-36*. New Haven.
- Mahadevan, Iravatham 1970. Dravidian parallels in proto-Indian script. *Journal of Tamil Studies* 2(1) : pp. 157-276.
- 1977. *The Indus Script : Texts, Concordance and Tables*. Archaeological Survey of India, New Delhi. (cited ASI Concordance 1977).
- 1981. Place signs in the Indus script. *Proceedings of the Fifth International Conference-Seminar of Tamil Studies*, Vol. 1, Sec. 2 : pp 2.91 - 2.107.
- 1983. The cult object on unicorn seals: a sacred filter? *Puratattva* 13 & 14 (1981-83) : pp. 165-186.
- 1986a. Towards a grammar of the Indus texts: 'intelligible to the eye, if not to the ears'. *Tamil Civilization* 4 (3 & 4) : pp. 15-30.
- 1986b. Agastya legend and the Indus civilization. *Journal of Tamil Studies* 30 : pp. 24-37.
- 1998. Phonetic value of the arrow sign in the Indus script. *Journal of the Institute of Asian Studies* 15 (2) : pp. 69-74.
- 2003. *Early Tamil Epigraphy*. Cre-A, Chennai, and Harvard University, USA.
- 2008. How did the 'great god' get a 'blue neck'? A bilingual clue to the Indus Script. *Journal of Tamil Studies* 74 : pp. 81-96.
- 2009a. Vestiges of Indus Civilisation in Old Tamil. *Proceedings of the Tamilnadu History Congress*, 16th Annual Session, Tiruchirapalli. pp. 19-38.
- 2009b. Meluhha and Agastya : Alpha and Omega of the Indus Script. *Journal of Tamil Studies* 76 : pp. 89-110.
- 2010. Harappan Heritage of Andhra: A New Interpretation. *International Journal of Dravidian Linguistics* 39(1) : pp. 9-17.
- 2011. *Akam and Puram* : Address Signs of the Indus Script. *International Journal of Dravidian Linguistics* 40(1) : pp. 81-94.
- Mahadevan, V. 2009. *Civapātacēkaraṇiṅ Tañcai-k-kalveṭṭuka!* [Texts of Rajaraja's Inscriptions at the Big Temple, Thanjavur, with commentary]. Chennai.



ROJA MUTHIAH
RESEARCH LIBRARY

3rd Cross Road, Central Polytechnic Campus, Taramani, Chennai 600 113. INDIA **Tel:** 91 44 2254 2551 / 52 **Fax:** 91 44 2254 2552
E-mail: rmrl@dataone.in **Website:** www.lib.uchicago.edu/e/su/southasia/rmrl.html

- Mahadeva Sastri, K. 1969. *Historical Grammar of Telugu*. Sri Venkateswara University, Anantapur.
- Marshall, J. 1931. *Mohenjodaro and the Indus Civilization*. 3 vols. London.
- Monier Williams 1899(1970). *A Sanskrit- English Dictionary*. Delhi. (cited MW).
- Nisha Yadav 2008. *List of Pairs and Triplets Signs in the Indus Script*. Tata Institute of Fundamental Research, Mumbai.
- Parpola, Asko 1994. *Deciphering the Indus Script*. Cambridge University Press.
- Parpola, Asko, B.M. Pande and Petteri Koskikallio 2010. *Corpus of Indus Seals and Inscriptions*. Vol.3, Part 1. Helsinki. (abbr. *CISI-3.1*).
- Possehl, G.L. 2002(2003). *The Indus Civilization : A Contemporary Perspective*. New Delhi.
- Qualls-Corbett, Nancy 1988. *The Sacred Prostitute : Eternal Aspect of the Feminine*. Toronto, Canada.
- Raghavaiyengar, M. 1907(2004). *Vēḷir Varalāru*. Chennai.
- Rao, L.S. 2007. A Note on Dancing Girl from Bhirrana, District Fatehabad, Haryana. *Man and Environment* 32 (1) : pp. 108-09.
- Ratnam, K. 2002. *Tamiḷnāṭṭu-p-paraivaikaḷ*. Chidambaram.
- Samy, P.L. 1976. *Caṅka ilakkiyattil pulliṇaviḷakkam*. Chennai.
- Seetharaman, A.A. 2004. *Tamiḷaka-t-tolliyal cāṅrukaḷ*. vol.III. Thanjavur. ---2006. *Pāṅṅiyar Kācukaḷ*. Thanjavur. ---2008. *Tamiḷaka-t-tolliyal cāṅrukaḷ*. vol.IV. Thanjavur.
- Shah, Sayid Ghulam Mustafa and Asko Parpola 1991. *Corpus of Indus Seals and Inscriptions*. vol.2 . Helsinki. (abbr. *CISI-2*).
- Sorensen, S. 1904(2006). *An Index to the Names in the Mahābhārata*. Delhi. (cited *Mbh. Index*).
- Sundar, G. et al 2008. *The Indus Script : Text and Context*. Bulletin of the Indus Research Centre. No.1 (2008-09). Roja Muthiah Research Library, Chennai.
- Tamil Lexicon* 1926-36. In 6 vols. and a supplement. University of Madras, Madras.
- Tamiḷ-pirāmi kalveṭṭukaḷ* 2006. (ed.) T.S.Sridhar et al. Tamilnadu State Department of Archaeology, Chennai.
- Travancore Archaeological Series*, vol. I (cited *TAS-I*).
- Vats, M.S. 1940. *Excavations at Harappa*. 2 vols. Delhi.
- Venkataswamy, Mayilai Seenii 1966(2004). *Cēraṅ Cēṅkuṭṭuvaṅ*. Chennai.
- Wheeler, Mortimer 1953(1960). *The Indus Civilization*. Cambridge University Press.
- Zvelebil, Kamil 1970. *Comparative Dravidian Phonology*. Mouton, The Hague.